

DeVilbiss

By Binks



Catalogue
Catalog
Katalog
2025

autorefinishdevilbiss.com

BREATHABLE AIR
FILTRATION & CONTROL

SPRAY TECHNICIAN
RESPIRATORY PROTECTION

i-system SPRAY GUNS
& DIGITAL GAUGES

RECOMMENDED AIR CAP
& FLUID TIP SET-UPS

COMPLIANT
COATINGS

GPG FOR PRIMERS/FILLERS/SURFACERS

For full range of air caps and fluid nozzles see page 14

DVI FOR WATER/SOLVENT BASECOAT & CLEARCOAT

For full range of air caps and fluid nozzles see pages 4 & 6

PROLite FOR SPOT, SMART & PANEL REPAIR

For full range of air caps and fluid nozzles see page 8

A First stage 5 micron filter element.
Part No.: PROAIR-51

B Second stage 0.01 micron, breathing air filter element.
Max oil carryover @20°C of 0.01mg/m³. Part No.: PROAIR-52

C Third stage 0.003 micron, breathing air filter element.
Max oil carryover @20°C of 0.03mg/m³. Part No.: PROAIR-53

D Waist belt, breathing air, odour removal filter cartridge.
Part No.: PROV-27-K4

The DMG Aerodry guns significantly speed up waterborne drying times

DVI BASECOAT	4	GTI PRO	61
DVI CLEARCOAT	6	PRI PRO LITE	62
DVI-S	8	SRI PRO LITE	63
DVI-3 GUN CASE KIT	10	GPI	64
GPG & PROLITE AIRCAP NOZZLE NEEDLE KITS	11	GFG PRO	65
PROLITE GRAVITY	12	FLG-5	66
PROLITE SUCTION & PRESSURE	14	GTI PRO	67
PROLITE S	16	GTI PRO LITE	68
GPG	18	JGA PRO	69
FLG	20	GTI PRO	70
FLG	22	PRI PRO	71
SLG	24	SRI PRO	72
SLG	25	GTI PRO	73
DAGR	26	DAGR	74
TRU-CLEAN	28	CVI	75
TRU-CURE IR2S, IR3S, IR3L	29	GTIW-GTIG-PRI	76
TRU-CURE UV-LED	30	GTIP-GTIS	77
PRO CLEAN	31	SRI-SRIW	78
DMG	32	VRI PRO	79
DGI PRO POD	33	VRI PRO	80
DEKUPS EVO	34	JGA	81
DEKUPS	35	GFG	82
COVERALLS PREMIUM	36	PRO VISOR	83
PRO VISOR	38	CROMAX	84
PRO AIR - 1	40	DEBEER	85
PRO AIR - 2	41	DYNACOAT	86
PRO AIR - 3	42	DEVILBISS LECHLER	87
PRO AIR - 4	43	LECHLER	87
ECONOMY REGULATORS	44	LESONAL	88
PAINT CUPS	45	MIPA	89
HOSES	46	OCTORAL	90
KBII	50	PPG	91
DX PUMPS	52	SIKKENS	92
MXL PUMPS	54	SPIES HECKER	93
PFT	56	STANDOX	94
DVFR	58	SPIES HECKER	95
SHIM-MASK	59	CONDITIONS OF SALE	96
GTI PRO LITE	60	A GUIDE TO THE DSEAR AND ATEX DIRECTIVES	99

DVI Basecoat

- The DVI air caps, with advanced internal geometry, result in a perfectly balanced, consistent spray pattern for a perfect finish
- Reduced air pressure resulting in improved spray pattern control, atomisation consistency and improved transfer efficiency
- A new combined air inlet and air control valve with 12 x higher precision sensitivity for smoother air control
- Consistently achieves a narrow colour window for the closest colour matching
- New advanced fluid tip design reduces turbulence, minimising mottling/clouding



PRODUCT
+
Less noise for your comfort

PART NUMBER EXPLANATION



SPECIFICATIONS

DVI B+ 'HVLP Plus' Air Cap		DVI B 'HVLP' Air Cap	
Air Inlet Pressure	2.0 bar (29 psi)	Air Inlet Pressure	2.0 bar (29 psi)
Air Consumption	300 l/min (10.6 cfm)	Air Consumption	395 l/min (13.9 cfm)
Spray Pattern Length	325mm @ 200mm target	Spray Pattern Length	330mm @ 200mm target
Fluid Flow	140 - 190 g/min	Fluid Flow	130 - 180 g/min
Air Inlet Thread	1/4" Universal	Air Cap	Plated Brass
Cup Capacity	560 mls	Air Cap Retaining Ring	Black Anodised Aluminium
Weight (gun only)	470 gms	Fluid Tip	Stainless Steel
		Fluid Needle	Stainless Steel

DVI BASECOAT SPRAY GUN KITS

When ordering please specify the air cap of your choice (DVI B or DVI B+). Please specify fluid tip you require: 11, 12 or 13.

Part No	Description
DVI-U-000-11-B	Gun only DVI Kit with HVLP air cap & 1.1mm tip
DVI-C-000-12-B+	Gun and cup DVI kit with HVLP 'Plus' air cap & 1.2mm tip
DVI-U-BAR-11-B	Gun only digital DVI kit with HVLP air cap & 1.1mm tip
DVI-C-BAR-12-B+	Gun & cup digital DVI kit with HVLP 'Plus' air cap & 1.2mm tip
DVI-U-BAR-14-1+A	Gun only digital DVI kit with 1+A air cap & 1.4mm tip

Kit includes complete gravity feed spray gun, gravity cup (if ordered), paint filter, cleaning brush and maintenance tools.

ACCESSORIES

Part No	Description
704407	DVI B HVLP air cap and retaining ring
704408	DVI B+ HVLP 'Plus' air cap and retaining ring
704445	DVI-100-1+A air cap and retaining ring
704411	Fluid tip - size number 11
704412	Fluid tip - size number 12
704413	Fluid tip - size number 13
704414	Fluid tip - size number 14
704416	DVI fluid needle
704430	Minor service kit
704431	Major service kit
704429	Tool kit
704426	Digital gauge for spreader valve assembly for DVI - reads in BAR
MPV-60-K3	Pack of 3 male quick detach uni swivel - fits to gun air inlet
HAF-507	Lightweight in-line air filter
4900-5-1-K3	Pack of 3 cleaning brushes
905207	Pack of 5 gravity cup filters for GFC cups



DVI-B Plus Air Cap



DVI-B Air Cap



4900-5-1-K3



MPV-60-K3



704431

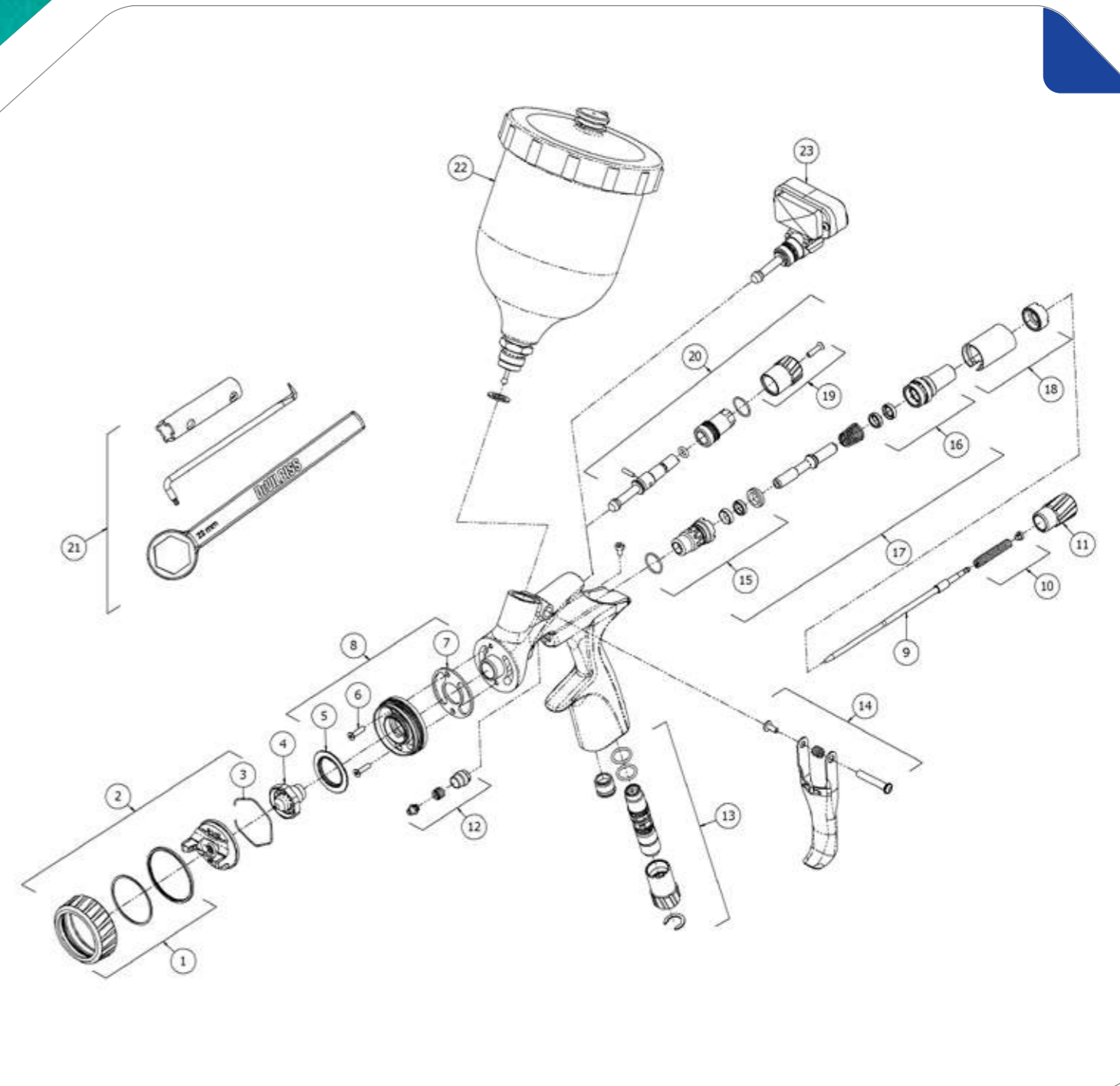

EXPLODED VIEW

Ref No	Description	Part No			
1	Retaining ring sub assembly	704425	13	Inline flow valve	704417
2	DVI-B HVLP Air Cap	704407	14	Tigger. Stud, spring & screw kit	704406
	DVI-B+ HVLP Air Cap	704408	15#	Front cage assembly	704422
3	Spring clip (kit of 5)	JGA-156-K5	16	Rear seal assembly	704423
4	Fluid tip 12	704412	17+	Air valve assembly	704424
	Fluid tip 13	704413	18	Sleeve kit	704428
	Fluid tip 14	704414	19	Spreader knob (non digital)	704419
5	Deflector plate	704402	20	Spreader valve assembly	704418
6+	Spray head screws (kit of 3)	704403	21	Tool kit	704429
7+	Gasket (kit of 2)	704401	22	Gravity cup (black)	GFC-515
8	Spray head kit	704400	23	Digital pressure gauge	704426
9	Fluid needle	704416		Service Kits	
10#+	Needle spring kit	704405		Minor service kit: Includes items marked # Plus air valve spring, spreader valve pin & o rings	704430
11	Fluid adjusting knob	704404		Major service kit: Includes items marked + Plus spreader valve pin & o rings	704431
12+	Packing, spring & packing nut kit	702731			

☰ **DVI Clearcoat**

- Delivers ultimate clearcoat application performance
- Sprays a uniform pattern that lays the clearcoat flat
- Atomizes effortlessly, producing an even distribution of super-fine particles
- Provides maximum comfort and easy use from set-up through the entire spraying process

PRODUCT +
Provides improved transfer efficiency and sprays with less noise



PART NUMBER EXPLANATION



SPECIFICATIONS

DVI C1+ 'HVLP Plus' Air Cap		Cup Capacity	560 mls
Air Inlet Pressure	2.0 bar (29 psi)	Weight (gun only)	470 gms
Air Consumption	285 l/min (10.0 cfm)	Air Cap	Plated Brass
Spray Pattern Length	325mm @ 200mm target	Air Cap Retaining Ring	Black Anodised Aluminium
Fluid Flow	140 - 190 g/min	Fluid Tip	Stainless Steel
Air Inlet Thread	1/4" Universal	Fluid Needle	Stainless Steel

DVI CLEARCOAT SPRAY GUN KITS

When ordering please specify the fluid tip you require: 1.0, 1.1, 1.2, 1.3 or 1.4.

Part No	Description
DVI-U-000-1.1-C1+	Gun only DVI Kit with HVLP air cap & 1.1mm tip
DVI-C-000-1.2-C1+	Gun and cup DVI kit with HVLP air cap & 1.2mm tip
DVI-U-BAR-1.1-C1+	Gun only digital DVI kit with HVLP air cap & 1.1mm tip
DVI-C-BAR-1.2-C1+	Gun & cup digital DVI kit with HVLP air cap & 1.2mm tip
DVI-C-BAR-1.2-C2+	Gun & cup digital DVI kit with HVLP air cap & 1.2mm tip
DVI-C-BAR-1.3-C2+	Gun & cup digital DVI kit with HVLP air cap & 1.3mm tip

Kit includes complete gravity cup and paint filter (if ordered) and maintenance tools.

ACCESSORIES

Part No	Description
704434	DVI C1+ HVLP air cap and retaining ring
704435	DVI C2+ HVLP air cap and retaining ring
704440	Fluid tip 1.0 mm
704441	Fluid tip 1.1 mm
704442	Fluid tip 1.2 mm
704443	Fluid tip 1.3 mm
704444	Fluid tip 1.4 mm
704416	DVI fluid needle
704430	Minor service kit
704431	Major service kit
704429	Tool kit
704426	Digital gauge for spreader valve assembly for DVI - reads in BAR
MPV-60-K3	Pack of 3 male quick detach uni swivel - fits to gun air inlet
HAF-507	Lightweight in-line air filter
4900-5-1-K3	Pack of 3 cleaning brushes
905207	Pack of 5 gravity cup filters for GFC cups



4900-5-1-K3



MPV-60-K3



704431

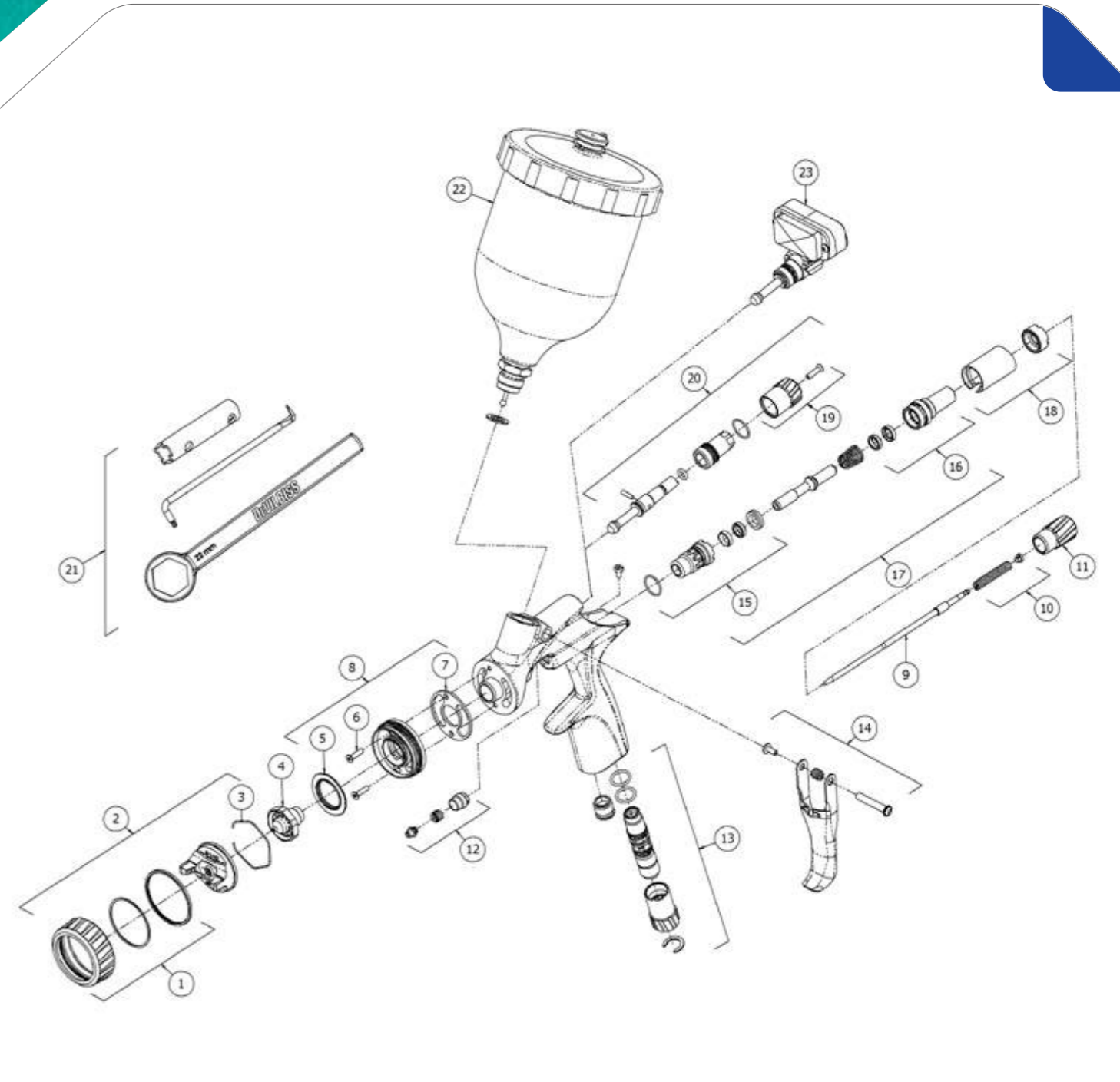

EXPLODED VIEW

Ref No	Description	Part No	
1	Retaining ring sub assembly	704425	
2	DVI-C1+ HVLP Air Cap	704434	
3	Kit of 5 retaining rings/JGA-156-K5	JGA-156-K5	
4	Fluid tip 1.0 mm	704440	
	Fluid tip 1.1 mm	704441	
	Fluid tip 1.2 mm	704442	
	Fluid tip 1.3 mm	704443	
	Fluid tip 1.4 mm	704444	
5	Deflector plate	704402	
6+	Spray head screws (kit of 3)	704403	
7+	Gasket (kit of 2)	704401	
8	Spray head kit	704436	
9	Fluid needle	704416	
10#+	Needle spring kit	704405	
11	Fluid adjusting knob	704404	
12+	Packing, spring & packing nut kit	702731	
13	Inline flow valve	704417	
14	Tigger, stud, spring & screw kit	704406	
15#	Front cage assembly	704422	
16	Rear seal assembly	704423	
17+	Air valve assembly	704424	
18	Sleeve kit	704437	
19	Spreader knob (non digital)	704419	
20	Spreader valve assembly	704418	
21	Tool kit	704429	
22	Gravity cup (plastic)	GFC-501	
23	Digital pressure gauge	704426	
Service Kits			
	Minor service kit: Includes items marked # Plus air valve spring, spreader valve pin & o rings	704430	
	Major service kit: Includes items marked + Plus spreader valve pin & o rings	704431	



PRODUCT

+
Improved transfer
efficiency saving
time, money, and
repair costs per
job

- Delivers ultimate clearcoat application performance
- Sprays consistent and homogeneous spray patterns
- Atomizes effortlessly with a selection of finely tuned air cap and fluid nozzle setups
- Provides maximum comfort and easy use from set-up through the entire spraying process
- Provides maximum comfort and ease of use with right the first time results

Table 1: Performance Guide

Air Cap Part Number	704451	704452	704453
Air Cap & Type	DVI-M1 Micro (HVLP)	DVI-S1 Plus (HVLP)	DVI-S2 (HVLP)
Recommended Air Pressure at Gun Inlet	1.00 bar (15 psi)	1.75 bar (25 psi)	1.75 bar (25 psi)
Air Consumption	50 L/min (1.8 scfm)	115 L/min (4.1 scfm)	130 L/min (4.6 scfm)
Fluid Flow	1 - 50 g/min	5 - 125 g/min	5 - 125 g/min
Pattern Height	60mm (2.4 in)	200mm (7.9 in)	5 - 125 g/min

DVI-S CLEARCOAT SPRAY GUN KITS

Part No	Description
704531	DVI-S HVLP Plus Kit (0.7,0.9, DVI-M1, cupped)
704532	DVI-S HVLP Plus Kit (1.0,1.2, DVI-S1, cupped)
704533	DVI-S HVLP Plus Kit (1.0,1.2, DVI-S2, cupped)

ACCESSORIES

Part No	Description
704451	DVI-M1 HVLP Plus Air Cap
704452	DVI-S1 HVLP Plus Air Cap
704453	DVI-S2 HVLP Plus Air Cap
704454	DVI-221-07M Fluid Tip (0.7mm)
704455	DVI-221-09M Fluid Tip (0.9mm)
704456	DVI-220-08S Fluid Tip (0.8mm)
704457	DVI-220-10S Fluid Tip (1.0mm)
704458	DVI-220-12S Fluid Tip (1.2mm)
704460	DVI-321M Fluid Needle
704459	DVI-320S Fluid Needle
704465	Fluid Adjusting Knob Kit
704467	Spreader Valve - Non Digital
704471	Air Valve Assembly
704477	DVI-M1 Test HVLP Plus Air Cap Kit
704478	DVI-S1 TEST HVLP Plus Air Cap Kit
704479	DVI-S2 TEST HVLP Plus Air Cap Kit
704403	Screw (Kit of 3)
905294	Needle Packing Kit (SN-404-K)
704405	Fluid Needle Spring Kit of 3
704417	Inline Flow Valve Assy

**DVI-S SMART/SPOT REPAIR GUN SYSTEM
COMPONENTS & ORDER NUMBERS**

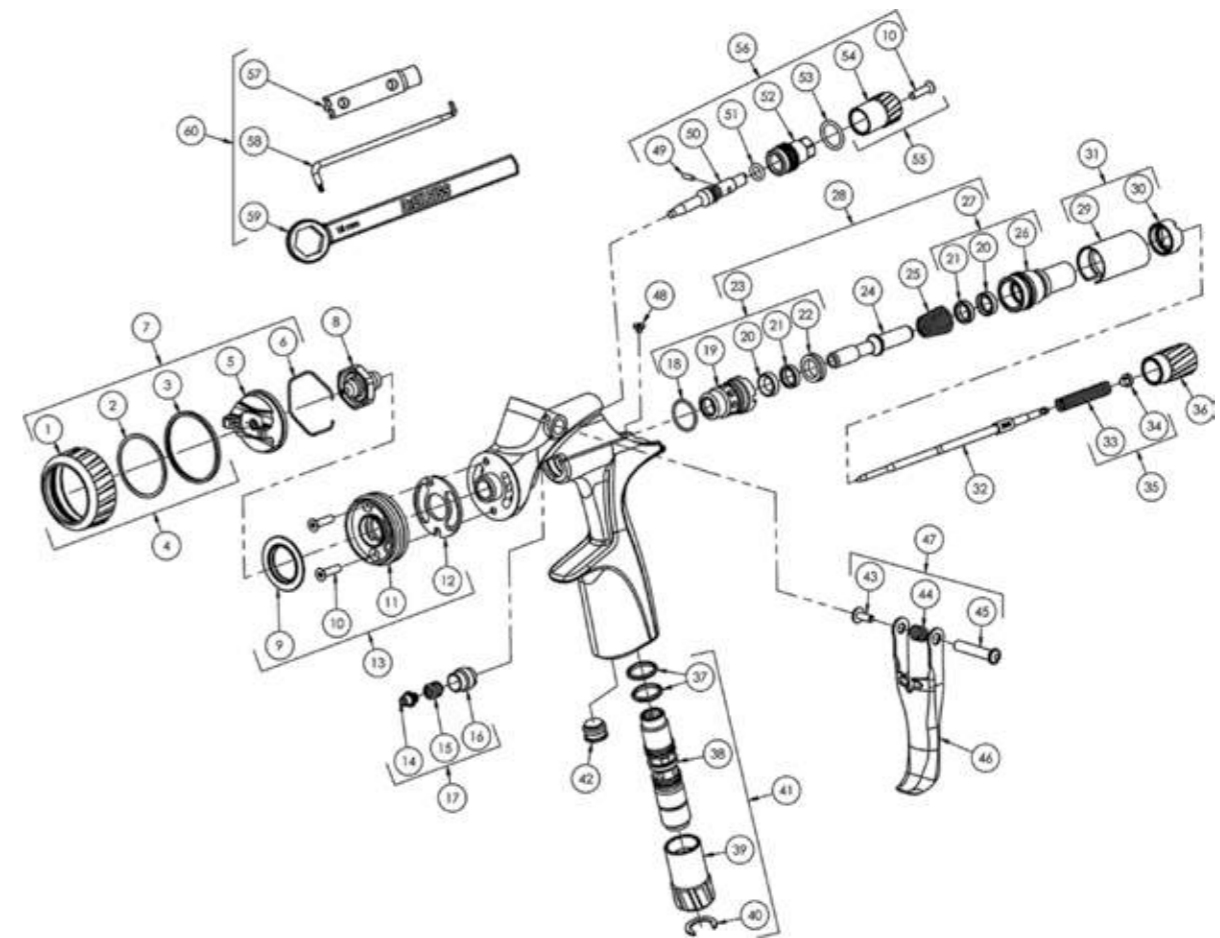

EXPLODED VIEW

Ref No	Description	Part No	Qty
1	Retaining Ring	-	1
2	Slip Ring	-	1
3	Retaining Ring Seal	-	1
4	Retaining Ring Sub Assembly	704472	1
5	Air Cap	-	1
6	Spring Clip (Kit of 5)	704480	1
7	Air Cap & Retaining Ring	See table 1	1
8	Fluid Nozzle	See table 2	1
9	Deflector Plate	704464	1
10+	Screw (Kit of 3)	704403	3
11	Sprayhead	-	1
12+	Gasket (Kit of 2)	704463	1
13	Spray Head Kit	704462	1
14	Needle Packing	-	1
15	Packing Spring	-	1
16	Packing Nut	-	1
17+	Packing, Spring & Packing Nut Kit	905294	1
18	O-Ring	-	1
19	Air Valve Cage	-	1
20	Seal	-	2
21*	Seal Guide	-	2
22*	Valve Seat	-	1
23#	Front Cage Assembly	704469 POA	1
24	Air Valve Stem	-	1
25#	Air Valve Spring	-	1
26	Rear Seal Housing	-	1
27	Rear Seal Assembly	704470	1
28+	Air Valve Assembly	704471	1
29	Identification Sleeve	-	1
30	Sleeve Nut	-	1
31	Sleeve Kit	704473	1
32	Fluid Needle	See table 2	1
33	Needle Spring	-	1
34	Spring Pad	-	1
35#+	Needle Spring Kit	704405	1
36	Fluid Adjusting Knob	704465	1
37	O-Ring	-	2
38	Flow Valve Body	-	1
39	Flow Valve Knob	-	1
40	Circlip	-	1
41	Inline Flow Valve	704417	1
42	Plug	-	1
43	Trigger Screw	-	1
44	Spring	-	1
45	Trigger Stud	-	1
46	Trigger	-	1
47	Trigger, Stud, Spring & Screw Kit	704466	1
48	Screw	-	1
49#+	Spreader Valve Pin	-	1
50	Spreader Valve Stem	-	1
51#+	O-Ring	-	1
52	Valve Body	-	1
53#+	O-Ring	-	1
54	Spreader Valve Adjusting Knob	-	1
55	Spreader Knob Kit	704468	1
56	Spreader Valve Assembly	704467	1
57	Valve Tool	-	1
58	Torx Driver	-	1
59	Tip Wrench	-	1
60	Tool Kit	704474	1

GRAVITY CUPS

Part No	Description
905311	Gravity Cup Kit
905202	Drip Check Lid (Kit of 5)
905308	Gravity Cup Lid (Kit of 2)
905309	Filter (Kit of 3)
905312	Funnel (Kit of 12)

SERVICE KITS

Part No	Description
704475	DVI's Minor Service Kit Includes Items Marked #
704476	DVI's Major Service Kit Includes Items Marked +

☰ **DVI-3 Gun Case Kit**

- A custom designed ruggedised gun case that is waterproof and corrosion free, featuring all the latest DeVilbiss technology

DVI-3 GUN CASE

Part No	Description
704704	DVI-3 Gun case kit

CONTENTS

Part No	Description
DVI-C-BAR-13-B+	1 x DVI Basecoat Digi Gravity Gun & Cup Kit
DVI-C-BAR-13-C1+	1 x DVI Clearcoat Digi Gravity Gun & Cup Kit
704532	1 x DVIS HVLP Plus Gravity Gun & Cup Kit
704407	1 x DVI-100-B, HVLP Air Cap Kit
704412	1 x DVI-200-12B Fluid Tip 1.2mm
704435	1 x DVI-100-C2+, HVLP Air Cap Kit
704442	1 x DVI-210-12C Fluid Tip 1.2mm
704458	1 x DVI-220-12S Fluid Tip 1.2mm
HAV-501-B	1 x Boxed Valve with gauge
DK-437	3-Gun Hard Case
704467	Spreader Valve - Non Digital
704471	Air Valve Assembly
704477	DVI-M1 Test HVLP Plus Air Cap Kit
704478	DVI-S1 Test HVLP Plus Air Cap Kit
704479	DVI-S2 Test HVLP Plus Air Cap Kit
704403	Screw (Kit of 3)
905294	Needle Packing Kit (SN-404-K)
704405	Fluid Needle Spring Kit of 3
704417	Inline Flow Valve Asssy



☰ **GPG & ProLite Aircap nozzle needle kits**

- Complete maintenance solution
- Boost performance
- Easy to install
- Ultimate precision
- Each kit includes : 1 aircap, 1 nozzle, 1 needle

Spraygun	Kit part number	Aircap	Nozzle	Needle Size
GPG Gravity	GPG-450-GPG1-1.2	GPG1	HE/HVLP	1,2
GPG Gravity	GPG-450-GPG1-1.3	GPG1	HE/HVLP	1,3
GPG Gravity	GPG-450-GPG1-1.4	GPG1	HE/HVLP	1,4
GPG Gravity	GPG-450-GPG1-1.5	GPG1	HE/HVLP	1,5
GPG Gravity	GPG-450-GPG1-1.6	GPG1	HE/HVLP	1,6
GPG Gravity	GPG-450-GPG1-1.8	GPG1	HE/HVLP	1,8
GPG Gravity	GPG-450-PR10-1.4	PR10	PRIMER	1,4
GPG Gravity	GPG-450-PR10-1.6	PR10	PRIMER	1,6
GPG Gravity	GPG-450-PR10-1.8	PR10	PRIMER	1,8
GPG Gravity	GPG-450-PR10-2.0	PR10	PRIMER	2
GPG Gravity	GPG-450-PR10-2.5	PR10	PRIMER	2,5
GPG Gravity	GPG-450-PR10-UV1	PR10	UV1	UV PRIMER
GPG Gravity	GPG-450-PR10-UV2	PR10	UV2	UV PRIMER
PROLite Gravity	PROL-455-TE10-11	TE10	HE	1,1
PROLite Gravity	PROL-455-TE10-12	TE10	HE	1,2
PROLite Gravity	PROL-455-TE10-13	TE10	HE	1,3
PROLite Gravity	PROL-455-TE10-14	TE10	HE	1,4
PROLite Gravity	PROL-455-TE10-15	TE10	HE	1,5
PROLite Gravity	PROL-455-TE20-11	TE20	HE	1,1
PROLite Gravity	PROL-455-TE20-12	TE20	HE	1,2
PROLite Gravity	PROL-455-TE20-13	TE20	HE	1,3
PROLite Gravity	PROL-455-TE20-14	TE20	HE	1,4
PROLite Gravity	PROL-455-TE20-15	TE20	HE	1,5
PROLite Gravity	PROL-455-T110-11	TE110	HE	1,1
PROLite Gravity	PROL-455-T110-12	TE110	HE	1,2
PROLite Gravity	PROL-455-T110-13	TE110	HE	1,3
PROLite Gravity	PROL-455-T110-14	TE110	HE	1,4
PROLite Gravity	PROL-455-HV30-12	HV30	HVLP	1,2
PROLite Gravity	PROL-455-HV30-13	HV30	HVLP	1,3
PROLite Gravity	PROL-455-HV30-14	HV30	HVLP	1,4
PROLite Suction	PROL-456-TE10-16	TE10	HE	1,6
PROLite Suction	PROL-456-TE10-18	TE10	HE	1,8
PROLite Suction	PROL-456-TE10-20	TE10	HE	2
PROLite Suction	PROL-456-TE20-16	TE20	HE	1,6
PROLite Suction	PROL-456-TE20-18	TE20	HE	1,8
PROLite Suction	PROL-456-T110-16	TE110	HE	1,6
PROLite Suction	PROL-456-HV30-18	HV30	HVLP	1,8
PROLite Pressure	PROL-457-TE20-085	TE20	HE	0,85
PROLite Pressure	PROL-457-TE20-14	TE20	HE	1,4
PROLite Pressure	PROL-457-TE20-18	TE20	HE	1,8
PROLite Pressure	PROL-457-TE30-12	TE30	HE	1,2
PROLite Pressure	PROL-457-TE40-085	TE40	HE	0,85
PROLite Pressure	PROL-457-TE40-10	TE40	HE	1
PROLite Pressure	PROL-457-TE40-12	TE40	HE	1,2
PROLite Pressure	PROL-457-TE40-14	TE40	HE	1,4

PROLite Gravity

- Lightweight design delivers a uniform spray pattern and atomization distribution for an exceptional quality finish that professional painters demand
- Range of advanced air cap technologies for excellent application performance with the latest waterborne and solventborne coatings
- Environmental legislation-compliant atomization with high transfer efficiency resulting in significant paint savings
- Drop-forged aluminum, anodized gun body with removable air baffle for a longer working life

SPECIFICATIONS

Weight (gun only)	445g
Gun Body	Anodized Aluminium
Air Cap	Plated Brass
Air Cap Retaining Ring & Knobs	Clear Anodised Aluminium
Fluid Nozzle	Stainless Steel
Fluid Needle	Stainless Steel
Air Inlet Thread	1/4" Universal



PRODUCT
+
Ergonomic handle design with reduced trigger travel to decrease operator fatigue



PROLITE GRAVITY SPRAY GUN KITS

Part No	Description
905053	Gravity Gun & Acetal Cup Kit (PROLITE-GTE25-12-C)
905058	Gravity Gun & Acetal Cup Kit (PROLITE-GHV30-12-C)
905059	Gravity Gun & Acetal Cup Kit (PROLITE-GHV30-13-C)
905063	Gravity Gun & Acetal Cup Kit (PROLITE-GT110-12-C)
905064	Gravity Gun & Acetal Cup Kit (PROLITE-GT110-13-C)
905068	Gravity Gun & Acetal Cup Kit (PROLITE-GTE10-12-C)
905069	Gravity Gun & Acetal Cup Kit (PROLITE-GTE10-13-C)
905071	Gravity Gun & Acetal Cup Kit (PROLITE-GTE20-12-C)
905072	Gravity Gun & Acetal Cup Kit (PROLITE-GTE20-13-C)
905052	Gravity Gun & Acetal Cup Kit (PROLITE-GTE25-11-C)
905054	Gravity Gun & Acetal Cup Kit (PROLITE-GTE25-13-C)
905067	Gravity Gun & Acetal Cup Kit (PROLITE-GTE10-11-C)

ACCESSORIES

Part No	Description
905240	TE10 Air Cap Assembly with Retaining Ring
905241	TE20 Air Cap Assembly with Retaining Ring
905242	TE25 Air Cap Assembly with Retaining Ring
905245	T110 Air Cap Assembly with Retaining Ring
905238	HV30 Air Cap Assembly with Retaining Ring
905246	1.1mm Fluid Nozzle
905247	1.2mm Fluid Nozzle
905248	1.3mm Fluid Nozzle
905249	1.4mm Fluid Nozzle
905250	1.5mm Fluid Nozzle
905266	PROLite Gravity Fluid Needle
905281	Spray Gun Service/Repair Kit
905206	Seal & Pin Kit
905296	Gun Wrench, Torx & Flat Back Screwdriver, Cleaning Brush & Color ID Rings
DGIPRO-504-BAR-K	Digital Gauge for Spreader Valve Assembly (Bar readout)
905204	Acetal Gravity Cup - 560ml
905359	Aluminum Gravity Cup - 900ml
DPC-43	DeKups® Adaptor
SNF-43	SNAP N FLOW™ Adaptor



KGP-5-K5



4900-5-1-K3



MPV-60-K3



HAF-507



905281

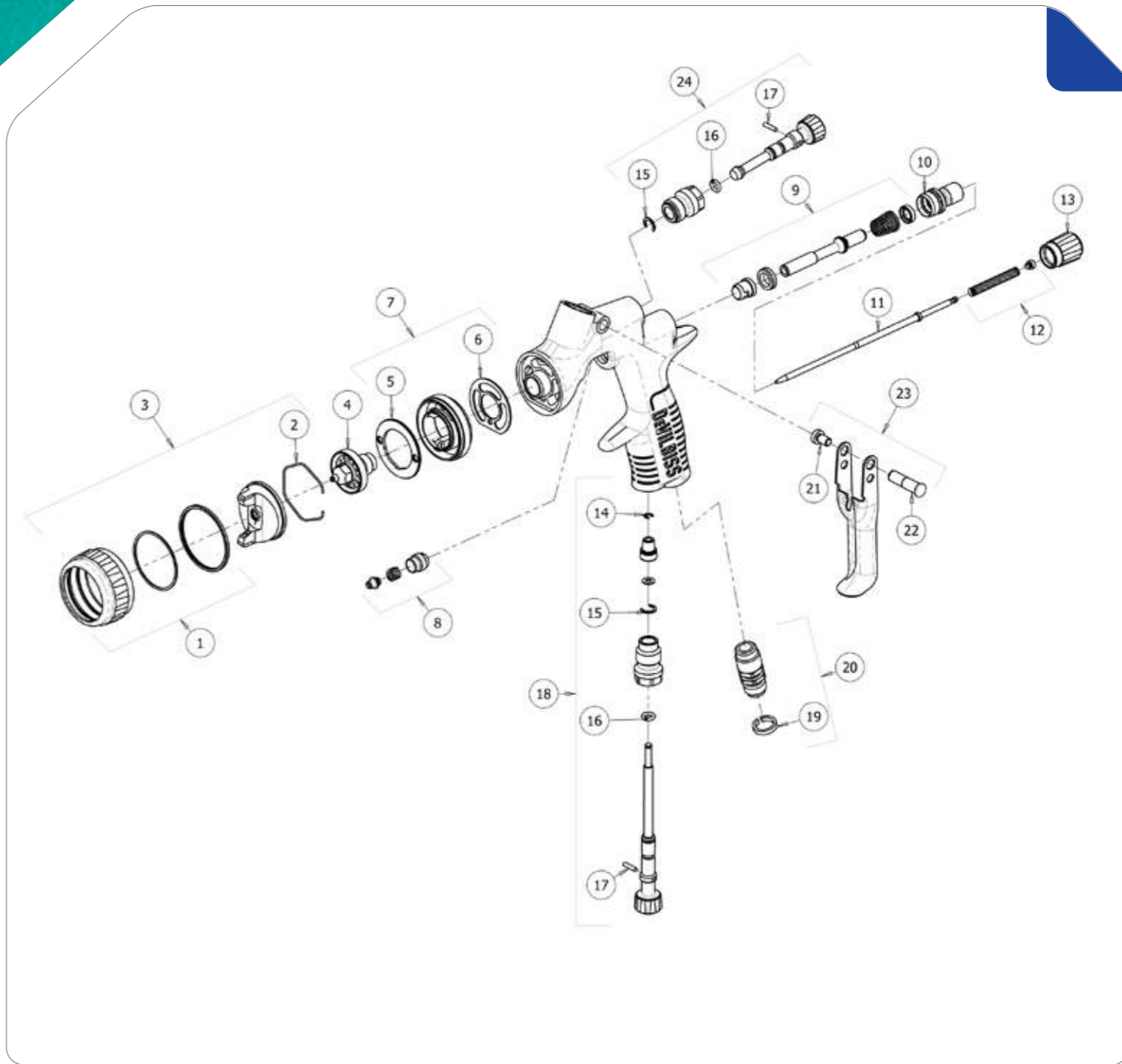

EXPLODED VIEW

Ref No	Description	Part No		Part No	
1	Retaining Ring Sub Assembly 1	905280	13	Fluid Adjusting Knob 1	905302
2	Spring Clip (kit of 5) 1	905208	14	Circlip (kit of 5) 1	905200
3	See Accessories (left) Air Cap & Retaining Ring 1		15*	† - Circlip 1	
4	See Accessories (left) Fluid Nozzle 1		16*	† - O Ring 1	
5	Baffle Plate 1	905297	17*	† - Spreader Valve Pin 1	
6*	Gasket (kit of 2) 1	905287	18	Airflow Valve 1	905276
7	Spray Head Kit 1	905303	19	Color ID Ring Kit (4 colors) 1	905289
8*	Packing, Spring & Packing Nut Kit 1	905294	20	Air Inlet 1	905305
9	Air Valve Assembly 1	905282	21*	- Trigger Screw 1	
10	Air Valve Body 1	905301	22*	- Trigger Stud 1	
11	Fluid Needle 1	905266	23	Trigger, Stud & Screw Kit 1	905306
12*	Needle Spring Kit 1	905283	24	Spreader Valve Assembly 1	905275

* 905281 - Spray Gun Repair Kit contains all the parts indicated with an asterisk. † 905206 - Seal & Pin Kit, kit of 5 (Items 15, 16, & 17).

PROLite Suction & Pressure

- Lightweight and comfortable handle design with reduced trigger travel to decrease operator fatigue.
- Advanced range of air cap technology for exceptional application performance with the latest waterborne and solventborne coatings.
- Environmental legislation-compliant atomization with high transfer efficiency resulting in significant paint savings.
- Forged aluminum gun body with unique QuickClean™ coating and a removable air baffle for a longer working life.



PRODUCT
+
Uniform atomization and spray pattern for ease of application.

SPECIFICATIONS

Weight (gun only)	500g
Gun Body	Anodized Aluminium
Air Cap	Plated Brass
Air Cap Retaining Ring & Knobs	Clear Anodised Aluminium
Fluid Nozzle	Stainless Steel
Fluid Needle	Stainless Steel
Air Inlet Thread	1/4" Universal



PROLITE SUCTION & PRESSURE SPRAY GUN KITS

Part No	Description	Air Cap
905100	Pressure gun only kit	PROLite-PC86-085-U
905101	Pressure gun only kit	PROLite-PC86-10-U
905102	Pressure gun only kit	PROLite-PC86-12-U
905103	Pressure gun only kit	PROLite-PC86-14-U
905104	Pressure gun only kit	PROLite-PC86-16-U
905105	Pressure gun only kit	PROLite-PC86-18-U
905106	Pressure gun only kit	PROLite-PC30-085-U
905107	Pressure gun only kit	PROLite-PC30-10-U
905108	Pressure gun only kit	PROLite-PC30-12-U
905109	Pressure gun only kit	PROLite-PC30-14-U
905110	Pressure gun only kit	PROLite-PC30-16-U
905111	Pressure gun only kit	PROLite-PC30-18-U
905112	Pressure gun only kit	PROLite-PC797-085-U
905113	Pressure gun only kit	PROLite-PC797-10-U
905114	Pressure gun only kit	PROLite-PC797-12-U
905115	Pressure gun only kit	PROLite-PC797-14-U
905116	Pressure gun only kit	PROLite-PC797-16-U
905117	Pressure gun only kit	PROLite-PC797-18-U
905118	Suction gun & cup kit	PROLite-SC86-14-C
905119	Suction gun & cup kit	PROLite-SC86-16-C
905120	Suction gun & cup kit	PROLite-SC86-18-C
905121	Suction gun & cup kit	PROLite-SC30-14-C
905122	Suction gun only kit	PROLite-SC30-16-U
905123	Suction gun only kit	PROLite-SC30-18-U
905141	Pressure gun only kit	PROLite-PHV30-12-U
905142	Pressure gun only kit	PROLite-PT110-085-10-U
905143	Pressure gun only kit	PROLite-PT110-12-14-U
905144	Pressure gun only kit	PROLite-PT110-16-18-U
905145	Pressure gun only kit	PROLite-PTE10-085-10-U
905146	Pressure gun only kit	PROLite-PTE10-12-14-U
905147	Pressure gun only kit	PROLite-PTE10-16-18-U
905148	Pressure gun only kit	PROLite-PTE20-085-10-U
905149	Pressure gun only kit	PROLite-PTE20-12-14-U
905150	Pressure gun only kit	PROLite-PTE20-16-18-U
905151	Pressure gun only kit	PROLite-PTE30-085-10-U
905152	Pressure gun only kit	PROLite-PTE30-12-14-U
905153	Pressure gun only kit	PROLite-PTE30-18-U
905154	Pressure gun only kit	PROLite-PTE40-085-10-U
905155	Pressure gun only kit	PROLite-PTE40-12-14-U
905156	Pressure gun only kit	PROLite-PTE40-16-18-U
905157	Suction gun & cup kit	PROLite-SHV30-16-18-20-C
905158	Suction gun & cup kit	PROLite-ST110-16-18-20-C
905159	Suction gun & cup kit	PROLite-STE10-16-18-20-C



KGP-5-K5



4900-5-1-K3



MPV-60-K3



HAF-507



905281

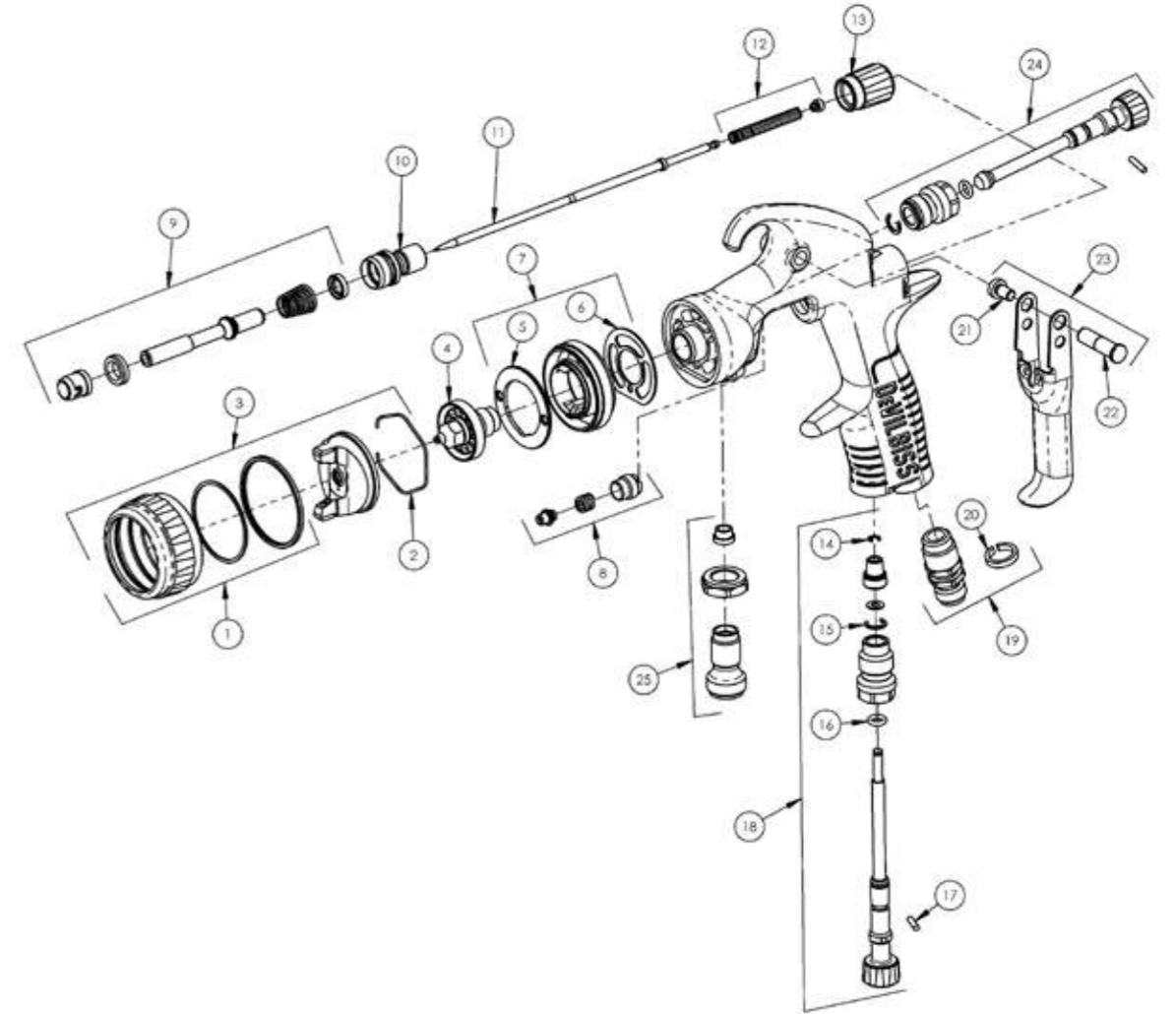

*Pressure Feed Only

EXPLODED VIEW

Ref No	Description	Part No
1	Retaining Ring Sub Assembly 1	905280
2	Spring Clip (kit of 5) 1	905208
3	See Accessories (right) Air Cap & Retaining Ring 1	
4	See Accessories Fluid Nozzle 1	
5	Baffle Plate 1	905297
6*	Gasket (kit of 2) 1	905287
7	Spray Head Kit 1	905303
8*	Packing, Spring & Packing Nut Kit 1	905294
9	Air Valve Assembly 1	905282
10	Air Valve Body 1	905301
11	See Accessories (left) Fluid Needle 1	
12*	Needle Spring Kit 1	905283
13	Fluid Adjusting Knob 1	905302
14	Circlip (kit of 5) 1	905200
15*	† - Circlip 1	
16*	† - O Ring 1	
17*	† - Spreader Valve Pin 1	
18	Airflow Valve 1	905276
19	Air Inlet 1	905305
20	Color ID Ring Kit (4 colors) 1	905289
21*	Trigger Screw 1	
22*	Trigger Stud 1	
23	Trigger, Stud & Screw Kit 1	905306
24	Spreader Valve Assembly 1	905275
25	Fluid Inlet Kit 1	905001

* 905281 - Spray Gun Repair Kit contains all the parts indicated with an asterisk. † 905206 - Seal & Pin Kit, kit of 5 (items 15, 16, & 17).

ACCESSORIES

Part No	Description
905243	TE30 Air Cap Assembly with Retaining Ring
905244	TE40 Air Cap Assembly with Retaining Ring
905234	C797 Air Cap Assembly with Retaining Ring
905238	HV30 Air Cap Assembly with Retaining Ring
905240	TE10 Air Cap Assembly with Retaining Ring
905241	TE20 Air Cap Assembly with Retaining Ring
905245	T110 Air Cap Assembly with Retaining Ring
905231	C30 Air Cap Assembly with Retaining Ring
905235	C86 Air Cap Assembly with Retaining Ring
905274	PROLite P/S Fluid Needle for 1.6, 1.8 & 2.0mm Suction Feed PRO-200s
905281	Spray Gun Service/Repair Kit
905206	Seal & Pin Kit
905296	Gun Wrench, Torx & Flat Back Screwdriver, Cleaning Brush & Color ID Rings
905353	Suction Cup & Lid Assembly

PROLite S

- Lightweight design delivers a uniform spray pattern and atomization distribution for an exceptional quality finish that professional painters demand.
- Range of advanced air cap technologies for excellent application performance with the latest waterborne and solventborne coatings.
- Environmental legislation-compliant atomization with high transfer efficiency resulting in significant paint savings.
- Drop-forged aluminum, anodized gun body with removable air baffle for a longer working life.

SPECIFICATIONS

Weight (gun only)	395g
Gun Body	Anodized Aluminium
Air Cap	Plated Brass
Air Cap Retaining Ring & Knobs	Clear Anodised Aluminium
Fluid Nozzle	Stainless Steel
Fluid Needle	Stainless Steel
Air Inlet Thread	1/4" Universal



PRODUCT

Ergonomic handle design with reduced trigger travel to decrease operator fatigue



PROLITES GRAVITY SPRAY GUN KITS

Part No	Description
905083	Gravity Gun & Cup Kit (PROLITE-S-HV5-08-C)
905084	Gravity Gun & Cup Kit (PROLITE-S-HV5-10-C)
905085	Gravity Gun & Cup Kit (PROLITE-S-HV5-12-C)
905086	Gravity Gun & Cup Kit (PROLITE-S-HV5-14-C)
905087	Gravity Gun & Cup Kit (PROLITE-S-TE5-08-C)
905088	Gravity Gun & Cup Kit (PROLITE-S-TE5-10-C)
905089	Gravity Gun & Cup Kit (PROLITE-S-TE5-12-C)
905090	Gravity Gun & Cup Kit (PROLITE-S-TE5-14-C)
905091	Gravity Gun & Cup Kit (PROLITE-S-RS1-08-C)
905092	Gravity Gun & Cup Kit (PROLITE-S-RS1-10-C)
905093	Gravity Gun & Cup Kit (PROLITE-S-RS1-12-C)
905094	Gravity Gun & Cup Kit (PROLITE-S-RS1-14-C)
905095	Gravity Gun & Cup Kit (PROLITE-S-MC1-06-C)

ACCESSORIES

Part No	Description
905316	TE5 Air Cap with Retaining Ring Assembly
905313	HV5 Air Cap with Retaining Ring Assembly
905314	MC1 Air Cap with Retaining Ring Assembly
905315	RS1 Air Cap with Retaining Ring Assembly
905317	0.8mm Fluid Nozzle
905318	1.0mm Fluid Nozzle
905319	1.2mm Fluid Nozzle
905320	1.4mm Fluid Nozzle
905323	PROLite-S Fluid Needle for 0.8 & 1.0mm Nozzles
905324	PROLite-S Fluid Needle for 1.2 & 1.4mm Nozzles
905321	0.6mm Micro Fluid Nozzle
905325	PROLite-S Micro Fluid Needle for 0.6mm Nozzle
905279	PROLite-S Spray Gun Repair Kit
905307	Torx & Flat Blade Screwdriver for Trigger & Needle Packing
HAV-501-B	In-Line Air Adjusting Valve
905311	Acetal Gravity Cup - 125ml
DPC-23	DeKups® Adaptor
SNF-23	SNAP N FLOW™ Adaptor



SPN-8-K2 & SRI-50-K2



MPV-60-K3

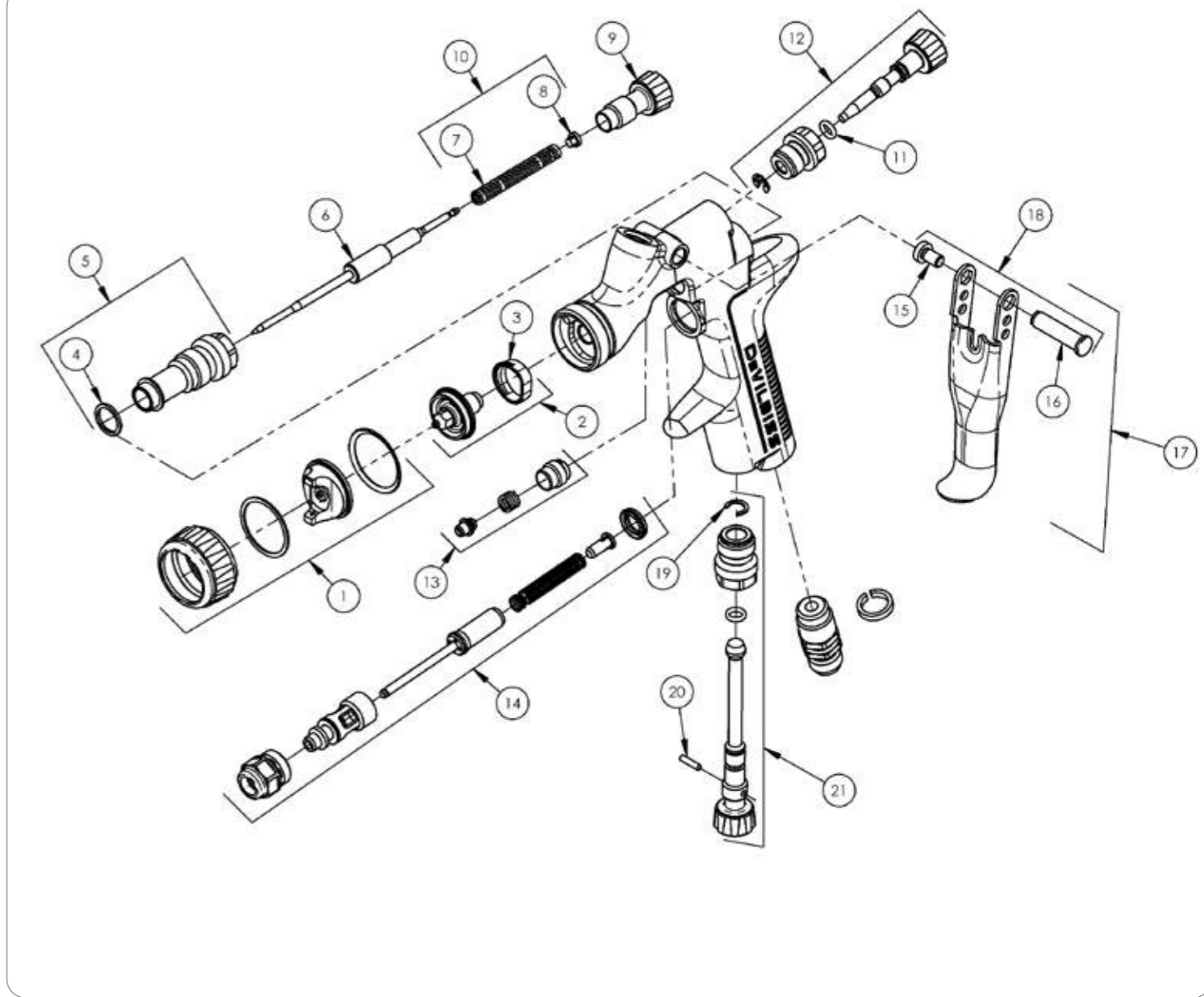

EXPLODED VIEW

Ref No	Description	Part No	
1	See Accessories (left) Air Cap & Retaining Ring 1		
2	See Accessories (left) Fluid Nozzle & Separator 1		
3*	Separator (kit of 5) 1	905322	
4*	- Body Bushing Seal 1		
5	Body Bushing & Seal 1	905300	
6	See Accessories (left) Fluid Needle 1		
7*	- Needle Spring 1		
8*	- Needle Spring Pad 1		
9	Fluid Adjusting Knob 1	905304	
10	Spring & Pad (kit of 3) 1	905299	
11*	- Spreader Valve Seal 1		
12	Spreader Valve Assembly 1	905326	
13*	Packing, Spring & Packing Nut Kit 1	905294	
14	Air Valve Assembly 1	905293	
15*	- Trigger Stud Screw (T20 Torx) 1		
16*	- Trigger Stud 1		
17	Trigger, Stud & Screw Kit 1	905298	
18	Stud & Screw Kit (kit of 5) 1	905295	
19*	- Circlip 1		
20*	- Spreader Valve Pin 1		

* 905279 - Spray Gun Repair Kit contains all the parts indicated with an asterisk

- Rugged anodized and forged aluminum gun body with lightweight aluminum controls for a long working life.
- Robust and smooth air valve design provides greater air and paint control to help ease fade-outs and blend-ins.
- Ultra high flow fluid nozzles provide superb versatility across the major range of viscosities.
- Suitable for all primers including the latest generation waterborne and UV materials for fast and efficient application.

AIR CAPS SPECIFICATIONS

Weight (gun only)	500g
Gun Body	Anodized Aluminium
Air Cap	Plated Brass
Air Cap Retaining Ring & Knobs	Clear Anodised Aluminium
Fluid Nozzle	Stainless Steel
Fluid Needle	Stainless Steel
Air Inlet Thread	1/4" Universal



PRODUCT
+
Renowned DeVilbiss atomization quality for even paint distribution.



GPG SPRAY GUN KITS

Part No	Description	
905000 to 905002	GPG Gravity Conventional Gun Kit (*see details)	C86
905003 to 905005	GPG Gravity Conventional Gun Kit (*see details)	C30
905006 to 905008	GPG Gravity High Efficiency Gun Kit (*see details)	GPG1
905029 to 905033	GPG Gravity High Efficiency Primer Gun Kit (*see details)	PR10
905034 to 905035	GPG Gravity High Efficiency UV Primer Gun Kit (*see details)	PR10

ACCESSORIES

Part No	Description
905229	GPG1 Air Cap Assembly with Retaining Ring
905230	GPG2 Air Cap Assembly with Retaining Ring
905228	C86 Air Cap Assembly with Retaining Ring
905227	C30 Air Cap Assembly with Retaining Ring
905209	PR10 Air Cap Assembly with Retaining Ring
905281	Spray Gun Repair Kit (Includes seals, packing & springs)
905206	Seal & Pin Kit
905204	Acetal Gravity Cup - 560ml
DPC-43	DeKups® Adaptor
SNF-43	SNAP N FLOW™ Adaptor

Multi-Purpose HE & HVLP Setup Components (GPG1 & GPG2 Air Caps)

905259 to 905264	1.2mm...1.8mm HE/HVLP Fluid Nozzle (*see details)
905267	Multi-Purpose Fluid Needle for 1.2, 1.3 & 1.4mm Nozzles
905268	Multi-Purpose Fluid Needle for 1.6 & 1.8mm Nozzles
905259	1.2 mm HE/HLVP Fluid Nozzle
905260	1.3 mm HV/HLVP Fluid Nozzle
905261	1.4 mm HV/HLVP Fluid Nozzle
905262	1.5 mm HV/HLVP Fluid Nozzle
905263	1.6 mm HV/HLVP Fluid Nozzle
905264	1.8 mm HV/HLVP Fluid Nozzle

Multi-Purpose Conventional Setup Components (C86 & C30 Air Caps)

905223 to 905225	1.4mm...1.8mm Conventional Fluid Nozzle (*see details)
905267	Multi-Purpose Fluid Needle for 1.4mm Nozzles
905268	Multi-Purpose Fluid Needle for 1.6 & 1.8mm Nozzles
905223	1.4 mm Conventional Fluid Nozzle
905224	1.6 mm Conventional Fluid Nozzle
905225	1.8 mm Conventional Fluid Nozzle

Primer Setup Components (PR10 Air Cap)

905213 to 905217	1.4mm...2.5mm Primer Fluid Nozzle (*see details)
905218	Primer Fluid Needle
905211	UV1 Primer Fluid Nozzle
905212	UV2 Primer Fluid Nozzle
905219	UV Primer Fluid Needle
905205	UV Gravity Cup - 560ml
PRO-46-K3	Protective Air Cap Cover for UV Materials (kit of 3)
905213	1.4 mm Primer Fluid Nozzle
905214	1.6 mm Primer Fluid Nozzle
905215	1.8 mm Primer Fluid Nozzle
905216	2.0 mm Primer Fluid Nozzle
905217	2.5 mm Primer Fluid Nozzle



KR-484-K10



MPV-60-K3



HAF-507



PRO-415-1



GFV-50-F

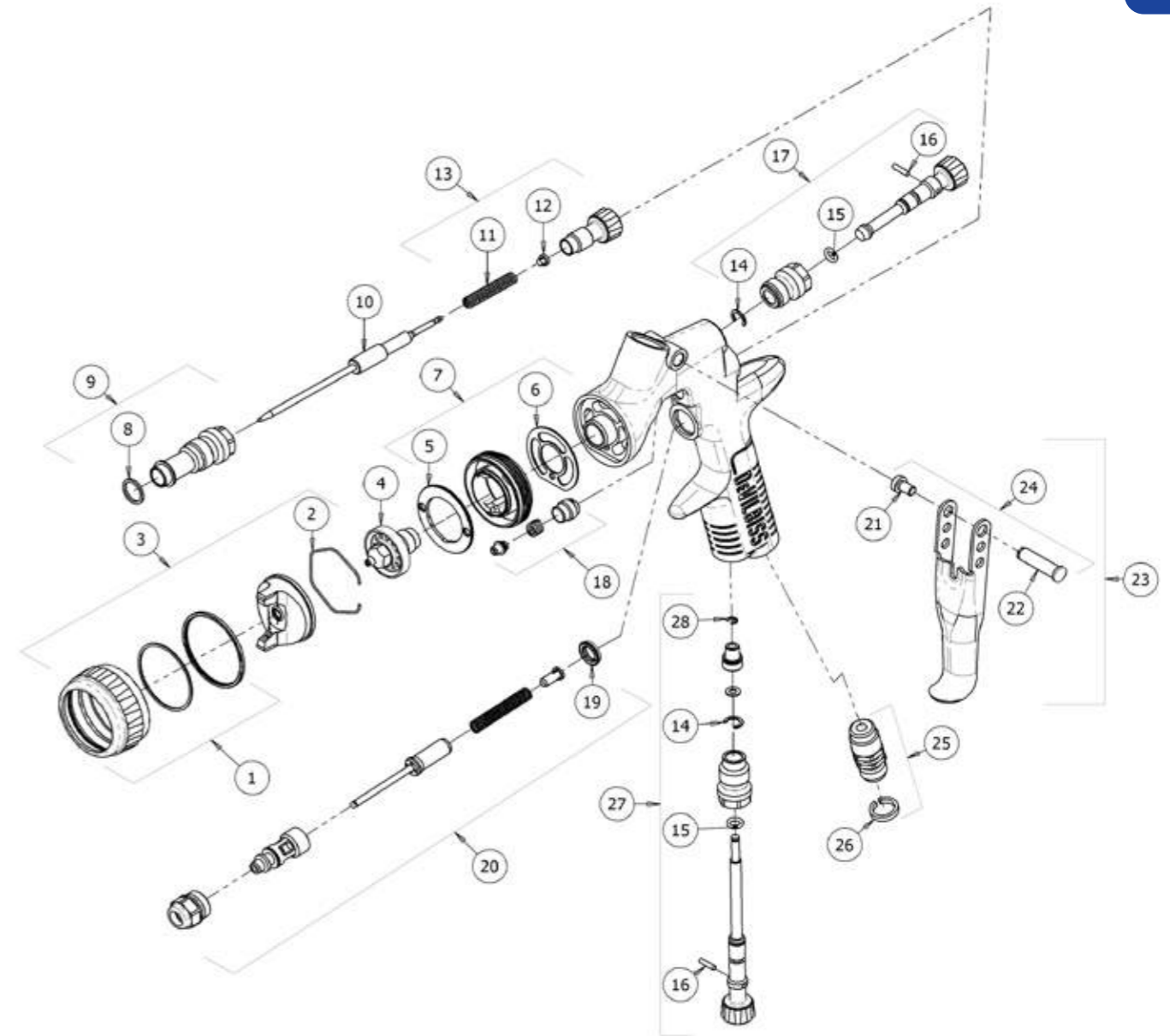

EXPLODED VIEW

Ref No	Description	Part No
1	Retaining Ring Sub Assembly 1	905329
2	Retaining Ring Sub Assembly 1	905208
3	See Accessories (left) Air Cap & Retaining Ring 1	905322
4	See accessories Fluids Nozzle 1	
5	Baffle Plate 1	905297
6*	Gasket (kit of 2) 1	905287
7	Spray Head Kit 1	905286
8*	Body Bushing Seal 1	
9	Body Bushing & Seal 1	905300
10	See Accessories (left) Fluid Needle 1	
11*	Needle Spring 1	
12*	Spring Pad 1	905327
13	Fluid Adjusting Knob, Spring & Pad Kit 1	905322
14*	Circlip 2	† -
15*	† - O Ring 2	
16*	† - Spreader Valve Pin 2	
17	preader Valve Assembly 1	905328
18*	Packing, Spring & Packing Nut Kit 1	905294
19	Air Valve Seal 1	905290
20	Air Valve Assembly 1	905293
21	Trigger Screw 1	
22*	Trigger Stud 1	
23	Trigger, Stud & Screw Kit 1	905288
24	Stud & Screw Kit (kit of 5) 1	905295
25	Air Inlet 1	905305
26	Color ID Ring Kit (4 colors) 1 1	905289
27	Airflow Valve 1	905277
28	Circlip (kit of 5) 1	905200

* 905279 - Spray Gun Repair Kit contains all the parts indicated with an asterisk

- Full control of pattern shape, fluid flow rate and air inlet pressure for consistent application.
- Smooth action trigger with exceptionally light pull for reduced fatigue during long operation.
- Efficient atomization technology for reduced material usages.
- Flexible setup options of gravity, suction or pressure feed to meet your needs.

SPECIFICATIONS

Weight (gun only)	465g
Gun Body	Anodized Aluminium
Air Cap	Plated Brass
Air Cap Retaining Ring & Knobs	Clear Anodised Aluminium
Fluid Nozzle	Stainless Steel
Fluid Needle	Stainless Steel
Air Inlet Thread	1/4" Universal



FLG5
High Efficiency
Air Cap

FLG SPRAY GUN KITS

Part No	Description
905166	Gravity Gun & Acetal Cup Kit (FLG-G5-13-C)
905167	Gravity Gun & Acetal Cup Kit (FLG-G5-14-C)
905168	Gravity Gun & Acetal Cup Kit (FLG-G5-18-C)
905169	Gravity Gun & Acetal Cup Kit (FLG-G5-20-C)

ACCESSORIES

Part No	Description
905332	FLG-5 Air Cap
905345	FLG Retaining Ring
905352	Fluid Nozzle Seal (pack of 10)
905335	FLG Gravity/Suction Feed Baffle Replacement Kit
905336	FLG Pressure Feed Baffle Replacement Kit
905337	FLG Gravity/Suction Spray Gun Repair Kit
905204	Acetal Gravity Cup - 560ml
905359	Aluminum Gravity Cup - 900ml
DPC-43	DPC-43 - DeKups® Adaptor (Gravity Feed Guns)
SNF-43	SNF-43 - SNAP N FLOW™ Adaptor (Gravity Feed Guns)

Gravity Feed Setup Components (FLG-5 Air Cap)

905340	1.3mm Gravity Fluid Nozzle
905341	1.4mm Gravity Fluid Nozzle
905344	1.8mm Gravity Fluid Nozzle
905342	2.0mm Gravity Fluid Nozzle
905348	FLG Gravity Fluid Needle for 1.3 & 1.4mm Nozzles
905349	FLG Gravity Fluid Needle for 1.8mm Nozzle
905350	FLG Gravity Fluid Needle for 2.0mm Nozzle



PRODUCT
+
Ergonomic gun handle shape for balance, grip and comfort.



4900-5-1-K3



HAV-501-B



KK-4584



KGP-5-K5

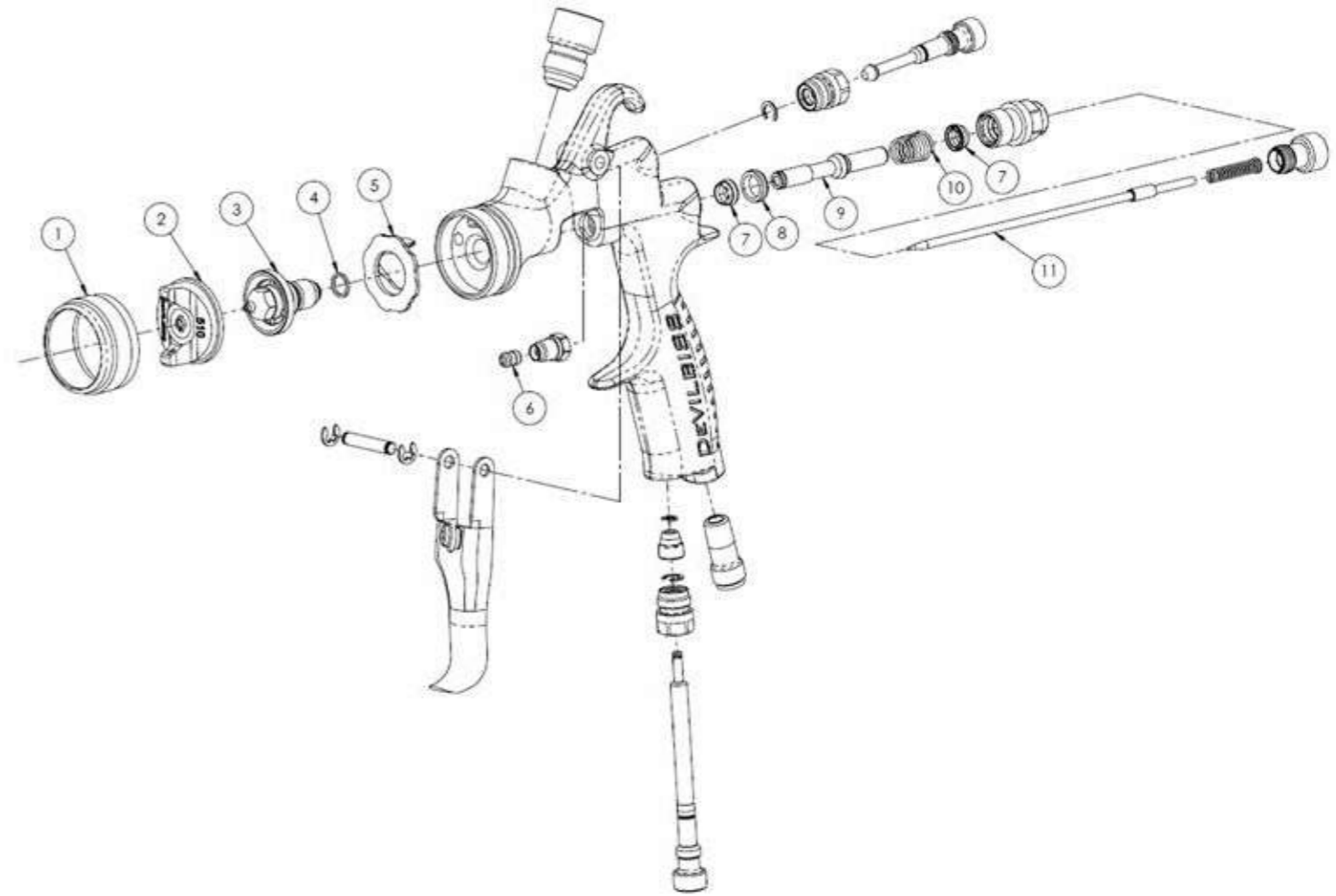

EXPLODED VIEW

Ref No	Description	Part No	
1	Retaining Ring 1	905345	7* † - Seal 2
2	See Accessories (left) Air Cap 1	905208	8* † - Valve Seat 1
3	See Accessories (left) Fluid Nozzle 1		9* † - Air Valve Stem 1
4*	† - Gasket 1	905352	10* † - Air Valve Spring 1
5*	† - Sprayhead Gravity & Suction 1 Sprayhead Pressure Only		11 See Accessories (left) Fluid Needle 1
6*	- Needle Packing 1	905339	12 † - Gasket 1

905335 - Gravity/Suction Gun Baffle Replacement Kit (Items 4 & 5)

905336 - Pressure Gun Baffle Replacement Kit (Items 4 & 5)

* 905337 - Gravity/Suction Gun: Seal, Baffle & Gasket Replacement Kit (Items 4, 5, 6, 7, 8, 9 & 10)

† 905338 - Pressure Gun Only: Seal, Baffle & Gasket Replacement Kit (Items 4, 7, 8, 9, 10 & 12)

- Full control of pattern shape, fluid flow rate and air inlet pressure for consistent application.
- Smooth action trigger with exceptionally light pull for reduced fatigue during long operation.
- Efficient atomization technology for reduced material usages.
- Flexible setup options of gravity, suction or pressure feed to meet your needs.

PRODUCT

+
Ergonomic gun handle shape for balance, grip and comfort.



SPECIFICATIONS

Weight (gun only)	485g
Gun Body	Anodized Aluminium
Air Cap	Plated Brass
Air Cap Retaining Ring & Knobs	Clear Anodised Aluminium
Fluid Nozzle	Stainless Steel
Fluid Needle	Stainless Steel
Air Inlet Thread	1/4" Universal



FLG5 - Suction High Efficiency Air Cap



FLG622 - Pressure High Efficiency Air Cap

FLG SPRAY GUN KITS

Part No	Description
905170	Pressure Gun Only Kit (FLG-P622-11-U)
905171	Pressure Gun Only Kit (FLG-P622-14-U)
905172	Pressure Gun Only Kit (FLG-P622-18-U)
905173	Suction Gun & Cup Kit (FLG-S5-18-C)

ACCESSORIES

Part No	Description
905332	FLG-5 Air Cap
905333	FLG-622 Air Cap
905345	FLG Retaining Ring
905352	Fluid Nozzle Seal (pack of 10)
905335	FLG Gravity/Suction Feed Baffle Replacement Kit
905336	FLG Pressure Feed Baffle Replacement Kit
905337	FLG Gravity/Suction Spray Gun Repair Kit
905338	FLG Pressure Spray Gun Repair Kit
905353	Suction Cup & Lid Assembly
DPC-43	DPC-43 - DeKups® Adaptor (Gravity Feed Guns)
SNF-43	SNF-43 - SNAP N FLOW™ Adaptor (Gravity Feed Guns)

Suction Feed Setup Components (FLG-5 Air Cap)

905344	1.8mm Suction Fluid Nozzle
905351	FLG Suction Fluid Needle for 1.8mm Nozzle

Pressure Feed Setup Components (FLG-622 Air Cap)

905343	1.1mm Pressure Fluid Nozzle
905341	1.4mm Pressure Fluid Nozzle
905344	1.8mm Pressure Fluid Nozzle
905346	FLG Pressure Fluid Needle for 1.1mm Nozzle
905347	FLG Pressure Fluid Needle for 1.4mm Nozzle
905351	FLG Pressure Fluid Needle for 1.8mm Nozzle



4900-5-1-K3



HAV-501-B



KK-4584



KGP-5-K5

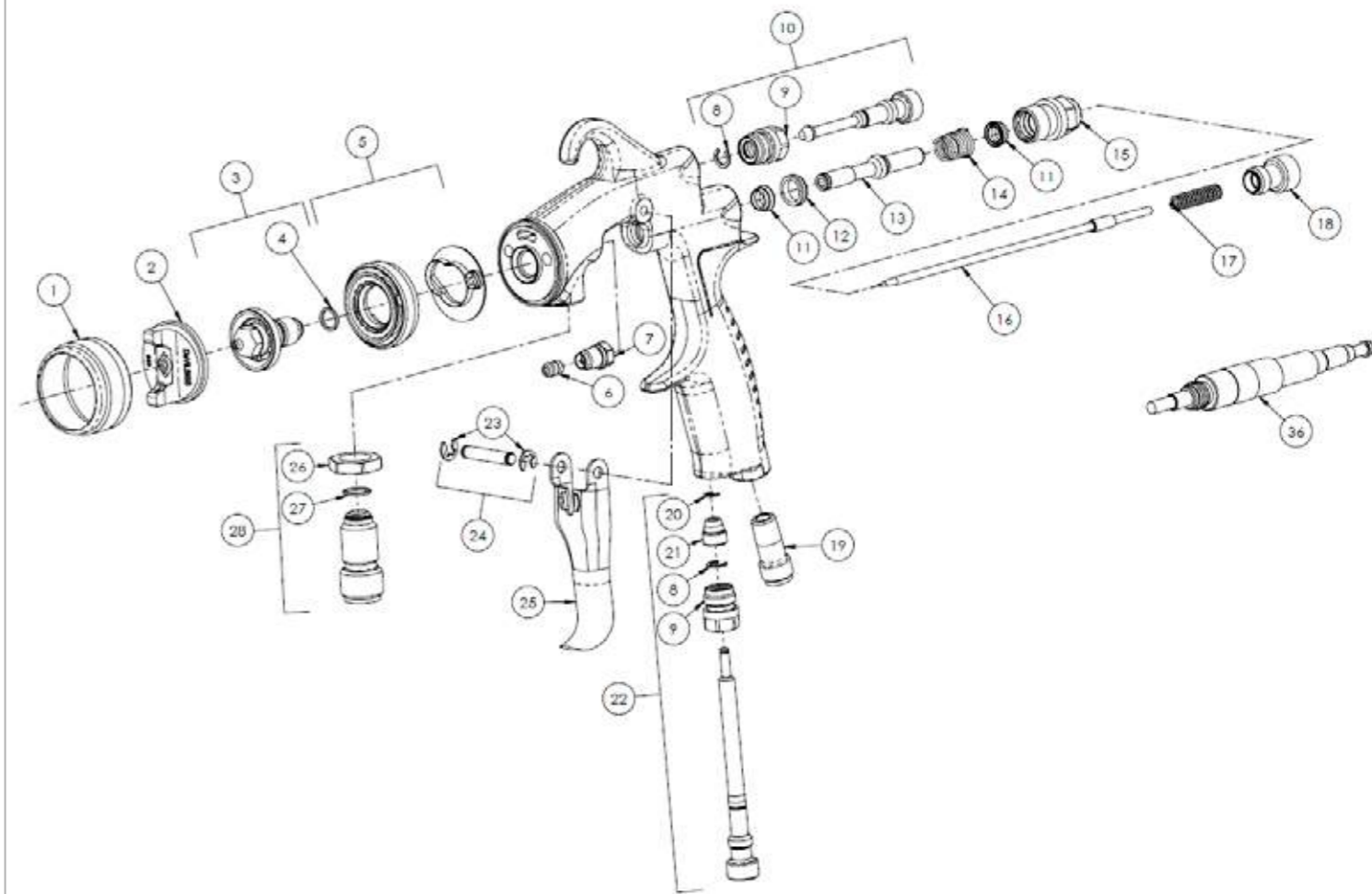

EXPLODED VIEW

Ref No	Description	Part No	7*	† - Seal 2
1	Retaining Ring 1	905345	8*	† - Valve Seat 1
2	See Accessories (left) Air Cap 1		9*	† - Air Valve Stem 1
3	See Accessories (left) Fluid Nozzle 1		10*	† - Air Valve Spring 1
4*	† - Gasket 1		11	See Accessories (left) Fluid Needle 1
5*	† - Sprayhead Gravity & Suction 1 Sprayhead Pressure Only		12	† - Gasket 1
6*	- Needle Packing 1			

905335 - Gravity/Suction Gun Baffle Replacement Kit (Items 4 & 5)

905336 - Pressure Gun Baffle Replacement Kit (Items 4 & 5)

* 905337 - Gravity/Suction Gun: Seal, Baffle & Gasket Replacement Kit (Items 4, 5, 6, 7, 8, 9 & 10)

† 905338 - Pressure Gun Only: Seal, Baffle & Gasket Replacement Kit (Items 4, 7, 8, 9, 10 & 12)

- General purpose gravity feed compliant spray gun
- Lightweight and strong aluminium construction
- Smooth fluid flow and pattern shape controls
- Ergonomically shaped handle for positive grip
- Precision engineered brass air cap provides excellent atomisation of most popular compliant automotive refinish materials
- The kit includes: a removable paint filter, a cleaning brush and universal spanner for easy cleaning and maintenance.

SPECIFICATIONS

Air Inlet Pressure	2.0 Bar
Air Consumption	250 l/min (8.8 cfm)
Air Inlet Thread	1/4" Universal
Cup Capacity	550ml
Weight (gun & cup)	Gun 480g / Cup 160g
Air Cap	Brass - Nickel Plated
Retaining Ring	Anodised Aluminium
Fluid Tip	Stainless Steel
Fluid Needle	Stainless Steel

Part No	Description
SLG-620-13-K10	Gravity Gun with 1.3mm fluid tip
SLG-620-18-K10	Gravity Gun with 1.8mm fluid tip
SLG-620-25-K10	Gravity Gun with 2.5mm fluid tip
SLG-450	Gravity Cup and Lid
SLG-40-K10	Needle Packing (Kit of 10)



PRODUCT
+
Fitted with a tough Acetal 550ml cup



- The kit comprises the SLG lightweight aluminium general purpose spray gun and the HVLP touch up/detailing gun
- The full size compliant SLG spray gun is fitted with a 1.3mm fluid tip and needle, a solid brass air cap and an aluminium 600ml paint cup
- The HVLP touch up/detailing gun comes complete with a 1mm fluid tip and needle, a solid brass air cap and a 250ml paint cup

SPECIFICATIONS

	Description	Touch Up
Air Inlet Pressure		2.0 Bar
Air Consumption		250 l/min (8.8 cfm)
Air Inlet Thread		1/4" Universal
Cup Capacity	600ml	250ml
Weight (gun & cup)	Gun 480g / Cup 160g	Gun 260g / Cup 90g
Air Cap		Brass - Nickel Plated
Retaining Ring		Anodised Aluminium
Fluid Tip		Stainless Steel
Fluid Needle		Stainless Steel

Part No	Description
SLG-650-K4	TWO GUN CASE KIT INCLUDES: Compliant Spray Gun (General Purpose), 1.3 mm, HVLP Spray Gun (Touch-Up), 1.0 mm, One 600 ml Cup, One 250 ml Cup Fluid Tip & Needle, 1.8 mm, Cleaning Brushes, Wrench, Air Adjusting Valve with Gauge

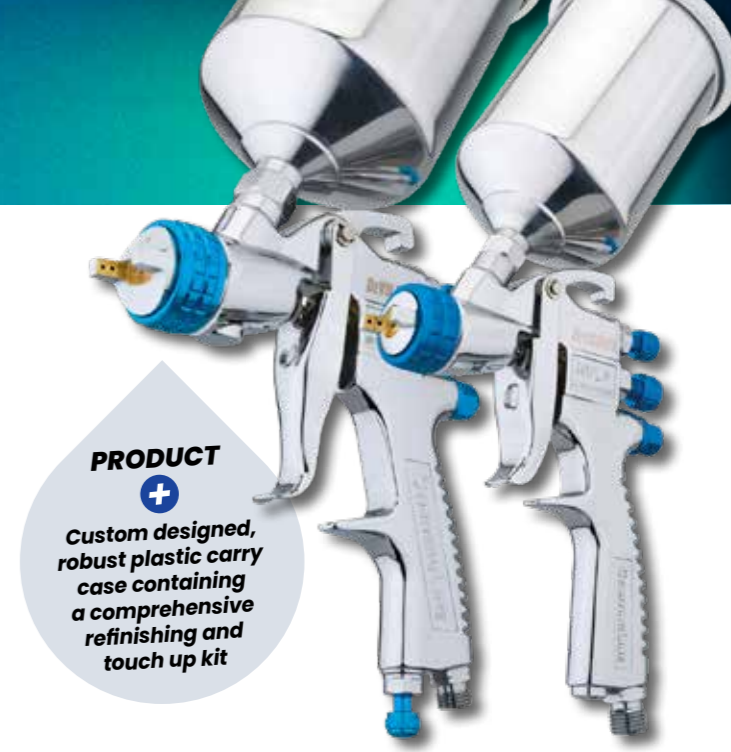

PRODUCT
+
Custom designed, robust plastic carry case containing a comprehensive refinishing and touch up kit



- Sprays most automotive paints and lacquers.
- Hairline detail to high paint-flow shading and gradual fades.
- Lightweight, well balanced with smooth double action trigger.
- Crown cap standard for fine lines and needle protection.
- Pre-set handle for precise control of paint flow.
- Removable 9 mls (1/3rd oz) gravity cup.
- Solvent proof fluid passages, PTFE needle packing.
- Precision made and hand tested in the U.S.A.



SPECIFICATIONS

Operating Pressure	1.3 – 3.5 bar (20 –50 psi)
Max inlet pressure	12 bar (175 psi)
Fluid tip	0.35mm
Cup Capacity	9 mls (1/3 fl/oz)
Airbrush plating	Nickel, copper, chrome
Needle Packing	PTFE (solvent proof)
Hose: Inside diameter	3.2 mm (1/8")
Air Hose connection	1/4" NPS (M)
Universal fluid threaded connector	3/8"

DAGR AIRBRUSH KIT AND ACCESSORIES

Part No	Description
DGR-501G-35	DAGR Gravity Airbrush - 0.35mm – 9 cc Cup/lid (1/3 fl/oz)
DGR-123	3m (10') Braided Nylon Air Hose with loose nut 1/4" swivel connections
DGR-121K	Repair Kit - 'O' Rings, needle spring and washers
DGR-124	3m (10') Braided Air Hose with QD
DGR-127	Quick Disconnect Kit

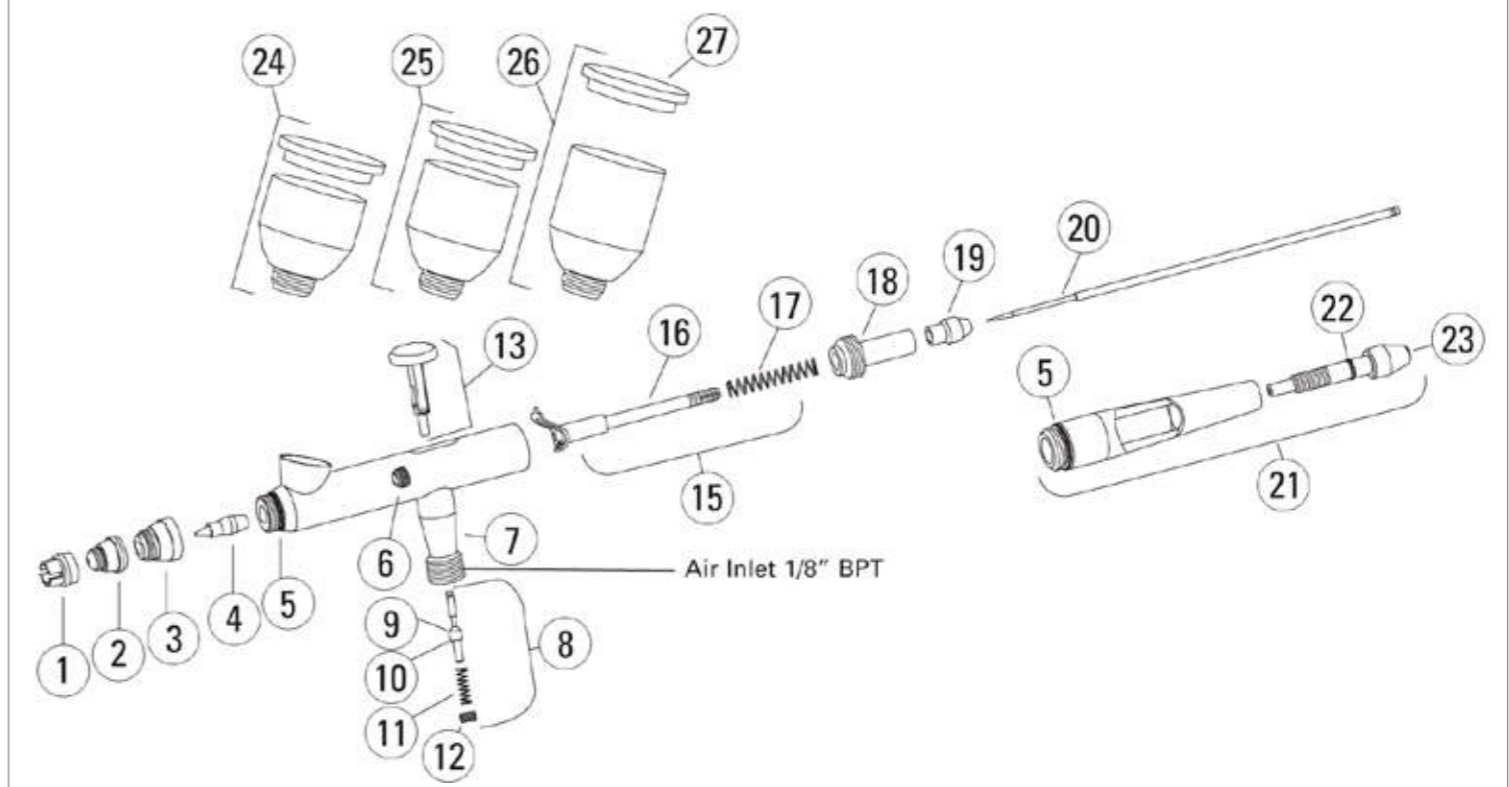

***DAGR REPAIR KIT (DGR-121K) INCLUDES:**

Ref No	Description
5	3 x O-rings (head cap & handle)
9	2 x Air valve o-ring
17	1 x Needle spring
22	1 x O-ring (pre-set needle knob)

Ref No	Description	Part No
1	Crown cap	DGR-101
2	Air cap (for .35mm nozzle)	DGR-103-35
3	Head cap	DGR-104
4	Nozzle (.35mm)	DGR-105-35
5*	O-ring (head cap & handle)	
6	Packing and nut assembly (PTFE)	DGR-106K
7	Air valve casing	DGR-107
8	Air valve kit	DGR-308K
9*	Air valve o-ring	
10	Air valve plunger	
11	Air valve spring	
12	Air valve nut	
13	Trigger	DGR-323
15	Needle guide, rocker & spring	DGR-110K
16	Needle guide and rocker	
17*	Needle spring	
18	Spring guide	DGR-111
19	Needle locknut	DGR-112
20	Needle (for .35mm nozzle)	DGR-113-35
21	Cutaway handle w/pre-set	DGR-114
22*	O-ring (pre-set needle knob)	
23	Pre-set needle knob	DGR-116
24	1/4 oz.(7 cc) cup and lid	DGR-117
25	1/3 oz.(9 cc) cup and lid (standard)	DGR-118
26	1/2 oz.(14 cc) cup and lid	DGR-119
27	Cup lid	DGR-120
28	DAGR repair kit	DGR-121K
30	O-ring (head cap & handle) kit (5)	DGR-18-K5

- Non-inverted cup mount
- Washes full paint channel of cup
- Washes outer top thread for cups with threaded lids
- Mount does not damage inside of gravity cups, creating pockets for coatings to build up
- Center mount exhaust port/vent 100mm (4") sizing is compatible with standard paint mixing rooms
- Supports strong, effective volatile extraction when the lid is open
- Robust & serviceable cleaning nozzle design
- Stainless Steel Washing Bay Construction

SPECIFICATIONS

Weight	30kg (66lbs.)
Dimensions	H: 1120 mm (44.1") W: 582 mm (22.9") D: 385 mm (15.2")
Air consumption - Auto cycle	<100 l/min (<3.5 cfm)
Air Consumption - Manual Cleaning	210 l/min (7.4cfm)
Avg. Ventilation Air Speed	0.8 m/sec (160ft/min)
Extraction Capacity	10m (33ft) extr. Duct 290m3/h (171cfm)
Air Supply	6 bar (87 psi)
Drum Size	Up to 25L (6.6 gal)
Flushing Media Types	Solvent-Based or Waterborne

Part No	Description
TC-GC-01	TRU-CLEAN SINGLE GUN CLEANER, AQ OR SOL

PRODUCT
+
High flow pump for effective cleaning



- Non-inverted cup mount
- Washes full paint channel of cup (mount does not block gun inlet)
- Washes outer top thread for cups with threaded lids (GFC-501)
- Mount does not damage inside of gravity cups, creating pockets for coatings to build up
- Center mount exhaust port/vent
- 100mm (4") sizing is compatible with standard paint mixing rooms
- Supports strong, effective volatile extraction when the lid is open (0.8m/sec.)
- Fit 4 drums of cleaning media - 2 for recirculation, 2 for final clean rinse
- Manual rinse brush quickly cleans waterborne coatings
- Lever allows selection of recirculating or clean rinse, to minimize waste

SPECIFICATIONS

Weight	35 kg (77 lbs.)
Dimensions	H: 1120 mm (44.1") / W: 1120 mm (44.1") / D: 385 mm (15.2")
Air consumption - Auto cycle	<100 l/min (<3.5 cfm)
Air Consumption - Manual Cleaning	370 l/min (14 cfm)
Avg. Ventilation Air Speed	0.8 m/sec (160 ft/m)
Extraction Capacity	10m (33ft) extr. Duct
Air Supply	290m3/h (171cfm)
Drum Size	6 bar (87 psi)
Flushing Media Types	Up to 20L (5.3 gal)
Flushing Media Types	Solvent-Based and waterborne

Part No
TC-GC-11



- Long-life IR lamps
- Easy to properly position lamps with laser guided pyrometer displaying surface temperature readout
- Stand and unit are sized to cure higher surfaces such as hood and roof
- Upgraded gas piston with long life seals precisely controls set point of upper arm
- IR3S and IR3L contain both dual and single lamp cassettes for easy adjustment and flexibility around curved parts without sacrifice to heat distribution

SPECIFICATIONS

Dimensions	H: 1480mm (58.3") W: 607mm (23.9") D: 750mm (20.5")
Weight	19kg (41.9 lbs.)
Rated Voltage	220-240 V, 50/60Hz Single Phase, 2000W
Heating Elements	2 quartz, IR short wave emitters
Fuse	16A slow, type C (UK13A) (NA 20A)
Max. Temperature - Operation	40°C (104°F)
Max. Temperature - Storage	70°C (158°F)



SPECIFICATIONS

Dimensions	H: 1630mm (64.2") W: 607mm (23.9") D: 750mm (20.5")
Weight	23kg (50.7 lbs.)
Rated Voltage	220-240 V, 50/60Hz Single Phase, 3000W
Heating Elements	3 quartz, IR short wave emitters
Fuse	16A slow, type C (UK13A) (NA 20A)
Max. Temperature - Operation	40°C (104°F)
Max. Temperature - Storage	70°C (158°F)



SPECIFICATIONS

Dimensions	H: 2600mm (102.4") W: 870mm (34.3") D: 1950mm (76.8")
Weight	47kg (103.6 lbs.)
Rated Voltage	220-240 V, 50/60Hz Single Phase, 3000W
Heating Elements	3 quartz, IR short wave emitters
Fuse	16A slow, type C (UK13A) (NA 20A)
Max. Temperature - Operation	40°C (104°F)
Max. Temperature - Storage	70°C (158°F)



Part No	Description
TC-IR6LT-02	TRU-CURE IR WITH PYROM 6 CS LG STAND UK
TC-IR6LT-03	TRU-CURE IR WITH PYROM 6 CS LG STAND EU

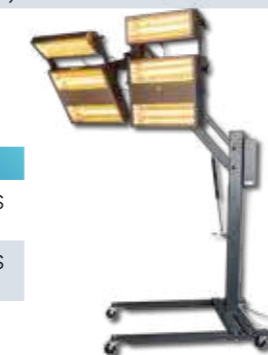

PRODUCT
+
Customizable timing of both full curing and flash off periods



Part No	Description
TC-IR2S-02	TRU-CURE IR NO PYROM 2 CS SM STAND UK
TC-IR2S-03	TRU-CURE IR NO PYROM 2 CS SM STAND EU

Part No	Description
TC-IR3S-02	TRU-CURE IR NO PYROM 3 CS SM STAND UK
TC-IR3S-03	TRU-CURE IR NO PYROM 3 CS SM STAND EU



Part No	Description
TC-IR3L-02	TRU-CURE IR NO PYROM 3 CS SM STAND UK
TC-IR3L-03	TRU-CURE IR NO PYROM 3 CS SM STAND EU
TC-IR3LT-02	TRU-CURE IR WITH PYROM 3 CS LG STAND UK
TC-IR3LT-03	TRU-CURE IR WITH PYROM 3 CS LG STAND EU

- Handle is made from glass-reinforced polymer for strong yet lightweight design
- Includes replaceable air filter, increasing the life of high cost LED
- Product is shipped in custom foam molded hard case for storage, with space for extra battery
- Packaging includes battery, charger, LED unit, spare filter, and UV protective eyewear

PRODUCT
+
Molded handle is comfortable, balanced, and ergonomic



SPECIFICATION

	UV-LED	BATTERY
Battery Type		Lithium-ion
Voltage	18.5 VDC	18.5 VDC
Max. Current		10 Ampere
Power	100 W	37 Wh / 2Ah
Weight	1.2 kg (2.6lbs)	0.54 kg (0.99lbs)
Operating Temp	0 - +35°C (0 - +95°F)	0 - +35°C (0 - +95°F)
Storage Temp	-20 - +70°C (-20 - +158°F)	"-20 - +45°C"
Charging Temp		+5 - 40°C (+5 - 104°F)
Wavelength Peak	395 nm	
Degree of Protection	IP 4X	IP 2X

Curing Intensity at 100mm	
Peak	160mW/cm2
Minimum at 120mm diameter	120mW/cm2

Part No	Description
TC-UV-02	TRU-CURE UV-LED UK KIT
TC-UV-03	TRU-CURE UV-LED EU KIT



- Faster, cleaner and more efficient than conventional gun wash machines.
- Can be used for waterborne and solvent applications.
- Significantly reduces solvent use and wastage dramatically reducing gun cleaning costs.
- Fresh solvent is used every time ensuring no contamination and rapid colour changes.
- The compact unit can be wall mounted to maximise floor space in the mix room.
- 500ml colour coded waterborne and solvent aerosols are easily clipped in and out of the machine.

PRODUCT
+
One 500ml can will clean up to 32 spray guns.



SPECIFICATIONS

Dimensions	H: 900 mm
	W: 245 mm
	D: 275 mm
Weight	9 kg
Max Air Pressure	8 bar (116 psi)
Min Air Pressure	6 bar (86 psi)
ATEX Safety Approval	CE Ex II 3G c IIA T6

PRO CLEAN GUN WASH MACHINE

Part No	Description
DEV-FHFZ1004	Pro Clean Waterborne Aerosol (Pack of 12)
DEV-FHFZ1013	Pro Clean Solvent Aerosol (Pack of 12)



SAVE TIME:	Less than a minute for a completely clean spray gun
SAVE COST:	One 500ml can of cleaner will clean up to 32 spray guns
SAVE SPACE:	Can be wall mounted to keep the floor space clear
SAVE WASTE:	Highly efficient, less than 16 ml of cleaning solution to clean a gun



- DMG guns multiply their intake by a factor of 7 to give generous air volumes.
- A fully adjustable aerodry stand provides full dryer flexibility.
- Solvent resistant for cleaning in gun wash machines.
- DMG guns feature intake debris filters and shut-off valves.

PRODUCT
+
A versatile system
to speed up the
drying process.



SPECIFICATIONS

Air consumption per gun at 3.4 bar (50 psi)	325 l/min (11.5cfm)
Recommended working pressure range	2-4 bar (30 – 60 psi)
Noise level at 3.4 bar (50 psi)	83 dba

DMG AIR DRYER SYSTEMS

Part No	Description
DMG-501-K	Single Air Dryer gun – boxed
DMG-620	Two gun stand system with hose



ACCESSORIES

Part No	Description
DMG-5-K3	Pack of 3 dryer inlet filters
DMG-520-K	Air dryer stand and hose
H-6086	10m Air hose with female quick detach and swivel/loose nut fittings
MPV-424	Female, self sealing, QD air line fitting
MPV-5	Male stem, QD air line fitting with 1/4" BSP (F)



- Perfectly positioned for easy checking.
- Accurate digital "bar" read-out of working pressure.
- Optimise your gun performance as you work.
- Accurate readings to within 0.05 bar (0.7 psi).
- Fully ATEX Approved – totally gun washer safe.
- Fitted in minutes - replaces standard spreader valve.

PRODUCT
+
Air flow "cheater"
valve adjusts
the gauge.



SPECIFICATIONS

Air Connections (M & F)	1/4" Universal (BSP/NPS)
Accuracy	+ or - 1%
Resolution steps	0.05 bar (0.7 psi)
Max static inlet pressure	12 bar (175 psi)
Housing	Die cast aluminium, nickel/chrome plated.
Readout window	Toughened glass
ATEX safety approval	CE Ex II IG EEx ia IIC T4

Part No	Description
704426	Digital gauge - Retrofit to DVI guns only
DGIPRO-503-BAR-K	DGi PRO pod gauge - Retrofit to GTI Pro guns only
DGIPRO-504-BAR-K	DGi PRO pod gauge - Retrofit to GTI Pro LITE guns only

Part No	Description
SN-52-K5	DGi Pro adjusting valve seals
MPV-60-K3	Male quick detach swivel
SN-57-K5	Air inlet aperture inserts



704426
(For DVI)



DGIPRO-504-BAR-K
(For 2016 GTI Pro &
all GTI Pro LITE models)



DGIPRO-503-BAR-K
(For Pre-2016 GTI Pro)

COVERALLS PREMIUM

THE HIGH EFFICIENCY CONSUMABLES RANGE

COVERALLS PREMIUM

- Unparalleled protection
- Ensures breathability and mobility
- Washable

Specification

Sizes M to 3XL
Wash up to 40°C



Part number	Description	Top Assembly or Services Parts
803531	DeVilbiss Prem Coverall, M	Service Parts
803532	DeVilbiss Prem Coverall, L	Service Parts
803533	DeVilbiss Prem Coverall, XL	Service Parts
803534	DeVilbiss Prem Coverall, 2XL	Service Parts
803535	DeVilbiss Prem Coverall, 3XL	Service Parts
803536	Knee Pads, Coverall, Set 2	Service Parts

OVERALLS

Part No	Description
DC-OV-M	Medium overall
DC-OV-L	Large overall
DC-OV-XL	Extra large overall
DC-OV-XXL	Extra extra large overall

BENEFITS

- Built in hood with pull cords.
- Vented under arm and back.
- Front and rear pockets with Velcro fastening.
- Elasticated waistband and cuffs for improved fit and operator comfort.
- Front knee pockets with Velcro fasteners for insertion of kneeling pads.
- Full length zip front fastening.
- Anti Static.
- Lint Free.
- Lightweight and comfortable to wear.
- Reusable.
- Washable.



ANTI-STATIC WIPE

Single-use treated wipe to eliminate static between refinish coats.



BUMPER PREP PAD

Single-use pre-saturated scuff pad for new unprimed bumpers & plastic parts.



BOOTH WALL COAT

Spray-on and peelable protective coating for booth walls and doors.



Part No	Description
DC-ASW-K12	Box of 12 individually packed Anti-Static Wipers

BENEFITS

- Reduces dirt imperfections on plastic parts caused by static.
- Lint free. • No VOCs.

EASY TO USE

- Simply wipe over the entire panel before spraying.

INNOVATIVE

- Improved metallic orientation from reduction of static charges which can cause metallics to orientate incorrectly.

DIRECTIONS FOR USE

- **NOTE:** For best results, the wipe must make contact with entire surface to be sprayed. USE DRY ONLY.
- 1) Carefully wipe the entire surface to be sprayed with the Devilbiss CLEAN™ Anti-Static Wiper.
- 2) For best results, use even, firm, overlapping strokes as if you were spraying the surface.

Part No	Description
DC-BPP-K12	Box of 12 individually packed Bumper Prep Pads

BENEFITS

- Reduces steps in bumper preparation processes, increasing efficiency.
- Provides comprehensive abrasion for better paint adhesion.
- Removes water-based and oil-based contaminants.

EASY TO USE

- Devilbiss CLEAN™ Bumper Prep Pad cleans, abrades and degreases in one easy step.
- Simply soak in water to activate the pad and start prepping your bumper.

INNOVATIVE

- The Bumper Prep Pad provides a more consistent scratch pattern and greatly improves paint adhesion.
- Additional preparation products may not be needed as the Bumper Prep Pad cleans, abrades, and degreases in one easy step.

BENEFITS

- The bright, white sprayable coating protects booth walls from overspray, helping to ensure clean, inclusion free paint jobs.
- Booth Wall Coat will last up to 6 months (maximum 500 bake cycles) before requiring removal and reapplication.
- Non sticky, will not shrink and doesn't crack.

EASY TO USE

- Booth walls don't have to be clean, just dry and clear of any washable coatings.
- Quick and easy to apply with a 1.8mm or larger gravity feed spray gun or 1.5mm or larger pressure feed gun.
- Masking is unnecessary if using Clear Glass Coat. Simply trim out the peelable Booth Coat from windows with a blade and spray Clear Glass Coat over.

INNOVATIVE

- Booth Wall Coat can be peeled off quickly and easily in large strips for ease of removal.
- Thanks to its water-based formulation, the spray gun can be cleaned in warm water.
- Booth Wall Coat is easy to touch up periodically to help keep the booth looking clean.

Maintaining a clean spray booth is vital to help ensure clean, inclusion free paint jobs, reducing or even eliminating the time and product wasted on paintwork rectification.

A clean, bright spray booth provides the perfect environment for the professional refinisher to achieve perfect blends and finishes.

Part No	Description
DC-BWC-K	Complete kit to spray entire booth including windows. 4 x bottles of Booth Wall Coat (3.78 litres each) , 1 x bottle of Clear Glass Coat (0.94 litres)

PRO VISOR

- Gun supply hose swivels both radially and laterally, ensuring better spray dynamics without the hose restricting the movement of the sprayer.
- The Pro Visor disperses breathing air gently around the lightweight visor at a positive pressure with no misting or discomfort, ensuring every sprayer can work at their best.
- The wrap around visor provides excellent and much wider peripheral vision than sprayers will be used to, while the removable peak can help reduce glare from spray booth lighting.
- A whistle is incorporated to warn the operator that an insufficient quantity of breathing air is being supplied to the Pro Visor.

PRODUCT
+
**Left or right sided
waist belt fitment
without having to
change the air fitting
configuration.**



SPECIFICATIONS

Protection	APF = 40 / NPF = 200
Carbon Filter Life	3 months
Supply Pressure	4.0 bar (60 psi) minimum to 7.0 bar (100 psi) maximum
Air Flow Rate	160 - 220 l/min (5.7 - 7.8 SCFM)
Noise level @ 220 l/min	80 db(A)
Approvals	PPE directive 89/686/EEC. Conforms to EN 14594:2005 Class 3A
Zone Classifications	Suitable for use in Zones 1 and 2 Hazardous Areas (gas groups IIA)

PRO VISOR OUTFIT

Part No	Description
PROV-650	Complete air fed visor outfit with waistbelt

Part No	Description
PROV-37-K	Belt & regulator
PROV-21-K	Peak
PROV-36-K10	Peel off visors pack of 10
PROV-36-K50	Peel off visors pack of 50
PROV-51-K	Belt and buckle assembly
PROV-38-K	Rigid Acetate visor, face seal and breathing air tube
PROV-26-K	Storage bag
PROV-27-K4	Filter element (pack of 4)
PROV-52-K2	Lint-free brow band (pack of 2)
PROV-41-K	Visor head piece & breathing air tube
PROV-30-K	Spacer, stud & knob (set of all sizes)
PROV-31-K	Filter cap & seal
PROV-32-K	Y-piece assembly
PROV-42-K	QD connector
PROV-406-K	Gun hose (1.2 m)
H-6085-QD	10 metre length air-hose complete with male and female QD's
H-6065	10 metre length air hose complete with re-usable fittings.
MPV-424	Female self-sealing, QD air line fitting
MPV-10	Male-stem, QD air line fitting with 1/4" BSP (M)
MPV-5	Male-stem, QD air line fitting with 1/4" BSP (F)
MPV-462	Female self-sealing QD fitting with 1/4" BSP (F)
MPV-463	Kit of 4 QD's fittings (2 male and 2 females)

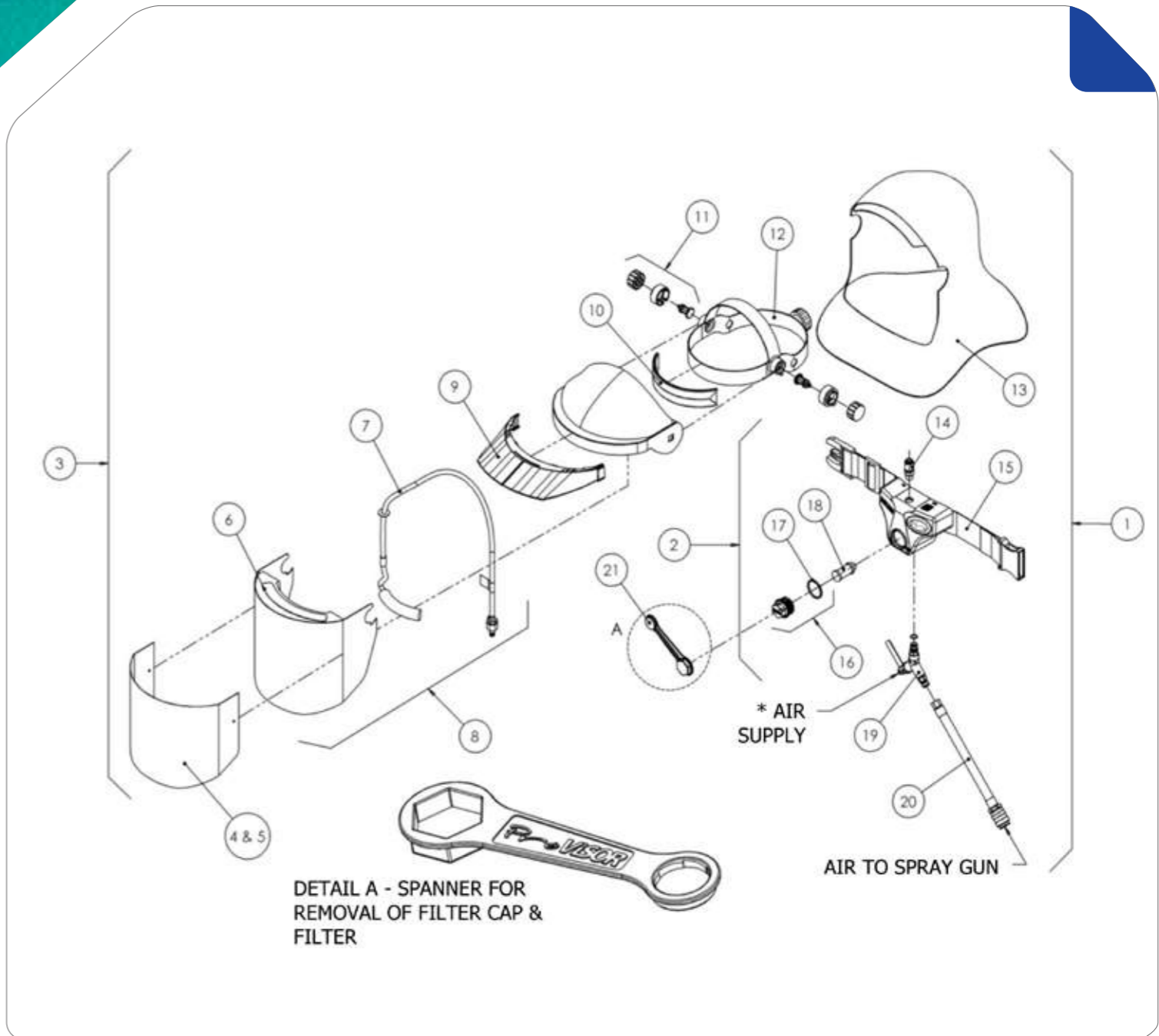

Ref No	Description	Part No
1	Pro-Visor Complete Unit	PROV-650
2	Belt And Regulator	PROV-37-K
3	Visor Head Piece & Breathing Air Tube	PROV-41-K
4	Tear-Off Visors Pack of 10	PROV-36-K10
5	Tear-Off Visors Pack of 50	PROV-36-K50
6	Rigid Acetate Visor & Face Seal	PROV-17-K
7	Breathing Air Tube Complete	PROV-24-K
8	Rigid Acetate Visor, Face Seal And Breathing Air Tube	PROV-38-K
9	Peak	PROV-21-K
10	Lint Free Brow Band (Pack of 2)	PROV-52-K2
11	Spacer, Stud & Knob (Set of All Sizes)	PROV-30-K
12	Adjustable Headpiece	PROV-40-K
13	Hood	PROV-39-K
14	QD Connector	PROV-42-K
15	Belt and Buckle	PROV-51-K
16	Filter Cap & Seal	PROV-31-K
17	Filter Cap Seal (Pack of 4)	PROV-34-K4
18	Filter Element (Pack of 4)	PROV-27-K4
19	Y-Piece Assembly	PROV-32-K
20	1.2m Hose (To Spray Gun)	PROV-406-K
21	Spanner for Filter & Cap	SPN-12-K
22	Storage Bag (not shown)	PROV-26-K

HOSES

Ref No	Description	Part No
	10M Air Hose - 5/16"ID Male & Female QD's	H-6085-QD
	10M Air Hose - 5/16"ID, 1/4" BSP G Swivel F Connectors	H-6065

≡ PRO AIR - 1

- Rolling diaphragm gives rapid response and sensitive air pressure control.
- Maximum airflow 3500 l/min (124 cfm).
- Two ball valve controlled outlets.
- Tamperproof, removable and lockable air pressure control knobs.

SPECIFICATIONS

Air Inlet Thread	1/2" BSP female
Regulated Outlets	2 Valved
Unregulated Outlets	N/A
Air Outlets (Ball Valves)	1/ 4" BSP (M)
Width (Overall)	185mm (7.2")
Height (Overall)	280mm (11")
Weight	2300 gms (81oz)
Capacity (maximum air flow)	3500 l/min (124 cfm)
Maximum Air Inlet Pressure	0-8 bar (0-116 psi)
Maximum Regulated Outlet Pressure	1/ 4" BSP (M)
Maximum Operating Temperature	80°C (176°F)
Pressure Gauge	0-11 bar (0-160 psi)
Gauge port	1/8" BSP (F)
Degree of Filtration (Output air quality class ISO8573-1)	3.7.4 (Down to 5 microns)
Drain Valve	Semi-Automatic
Maximum Pressure Drop	5% of Inlet Pressure

PRO AIR-1 REGULATOR

Part No	Description
PROAIR-1	2 Outlet Filter Regulator
DV-9420601	Filter bowl removal tool

Ref No	Description	Part No
1	Upper Cover Assembly	PROAIR-71
2	Filter (Air)	PROAIR-51
3	Metal Filter Bowl	PROAIR-72
4	Ball Valve	SER-3414-MF
5	Pressure Gauge	GA-319

PRODUCT
+
Provides air filtered to 5 microns.

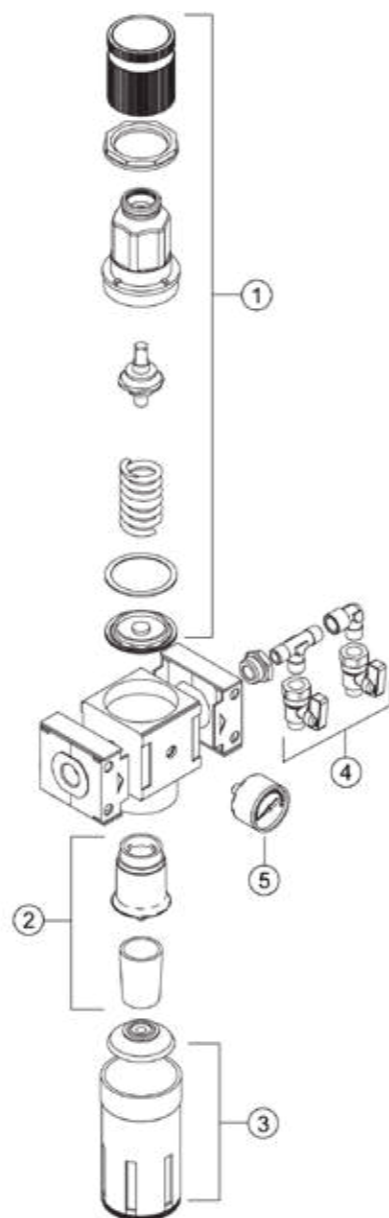

≡ PRO AIR - 2

- High air flows for conventional and compliant spray guns.
- Provides air filtered to 0.01 microns suitable for air-fed respiratory outfits.
- Maximum airflow of 900 l/min (32 cfm).
- Rolling diaphragm gives rapid response and sensitive air pressure control.

SPECIFICATIONS

Air Inlet Thread:	1/2" BSP female
Regulated Outlets	2 Valved
Unregulated Outlets	N/A
Air Outlets (Ball Valves)	1/ 4" BSP (M)
Width (Overall)	330mm (12.9")
Height (Overall)	280mm (11")
Weight	3375 gms (119 oz)
Capacity (maximum air flow)	900 l/min (32 cfm)
Maximum Air Inlet Pressure	13 bar (189 psi)
Maximum Regulated Outlet Pressure	0-8 bar (0-116 psi)
Maximum Operating Temperature	80°C (176°F)
Pressure Gauge	0-11 bar (0-160 psi)
Gauge port	1/8" BSP (F)
Degree of Filtration (Output air quality class ISO8573-1)	1.7.2 (Down to 0.01 microns *)
Drain Valve	Semi-Automatic
Maximum Pressure Drop	10% of Inlet Pressure

* Suitable for Breathing Air

PRO AIR-2 REGULATOR

Part No	Description
PROAIR-2	2 Outlet Filter Regulator Coalescer
DV-9420601	Filter bowl removal tool

Ref No	Description	Part No
1	Upper Cover Assembly	PROAIR-71
2	Filter (Air)	PROAIR-51
2a	Filter Element Only	-
3	Metal Filter Bowl	PROAIR-72
4	Ball Valve	SER-3414-MF
5	Pressure Gauge	GA-319
6	Fine Filter (Oil)	PROAIR-52
7	Isolation Valve	DV-8000035
8	Filter Kit (Includes Items 2, 6)	PROAIR-62

PRODUCT
+
Two ball valve controlled outlets.

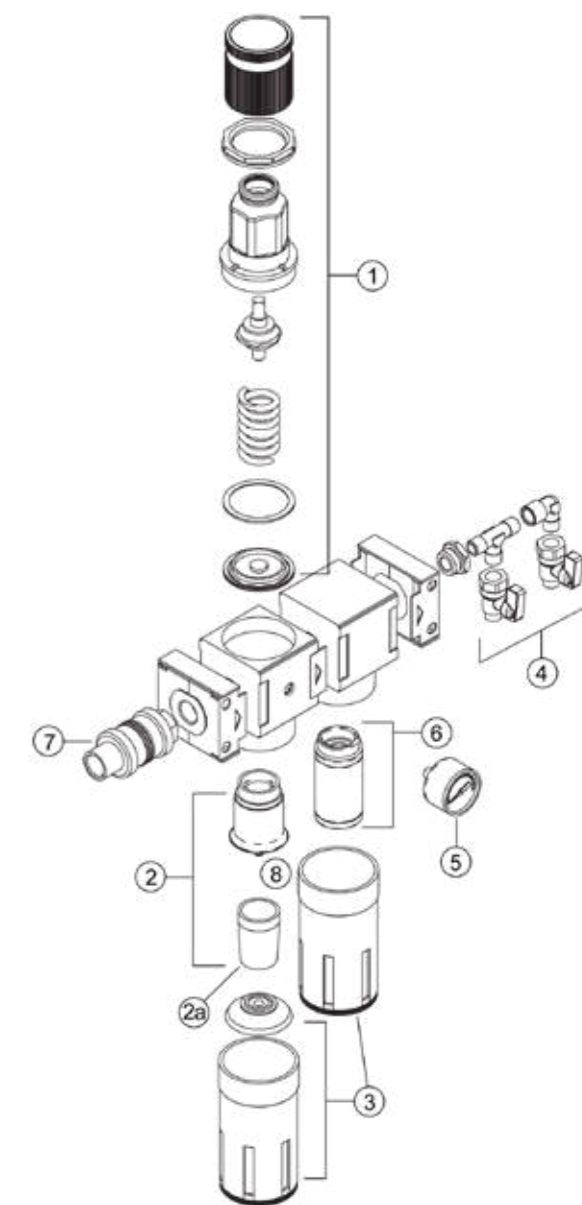

**PRO AIR-3
FILTER
REGULATOR
WITH ACTIVATED
CARBON FILTER**

ProAIR-3 DeVilbiss
By Binks

PRO AIR - 3



PRODUCT
+
**Two ball valve
controlled
outlets.**

- For conventional and compliant spray guns.
- Provides air filtered to 0.01 microns suitable for air-fed respiratory outfits.
- Activated carbon filter removes oil carry over to 0.003 microns.
- Maximum airflow of 900 l/min (32 cfm).
- Rolling diaphragm gives rapid response and sensitive air pressure control.

SPECIFICATIONS

Air Inlet Thread:	1/2" BSP female
Regulated Outlets	2 Valved
Unregulated Outlets	N/A
Air Outlets (Ball Valves)	1/ 4" BSP (M)
Width (Overall)	395mm (15.5")
Height (Overall)	280mm (11")
Weight	4205 gms (165 oz)
Capacity (maximum air flow)	900 l/min (32 cfm)
Maximum Air Inlet Pressure	13 bar (189 psi)
Maximum Regulated Outlet Pressure	0-8 bar (0-116 psi)
Maximum Operating Temperature	80°C (176°F)
Pressure Gauge	0-11 bar (0-160 psi)
Gauge port	1/8" BSP (F)
Degree of Filtration (Output air quality class ISO8573-1)	1.71 (Down to 0.003 microns *)
Drain Valve	Semi-Automatic
Maximum Pressure Drop	10% of Inlet Pressure

* Suitable for Breathing Air

PRO AIR-3 REGULATOR

Part No	Description
PROAIR-3	2 Outlet Filter Regulator Coalescer with activated carbon filter
DV-9420601	Filter bowl removal tool

Ref No	Description	Part No
1	Upper Cover Assembly	PROAIR-71
2	Filter (Air)	PROAIR-51
2a	Filter Element Only	-
3	Metal Filter Bowl	PROAIR-72
4	Ball Valve	SER-3414-MF
5	Pressure Gauge	GA-319
6	Fine Filter (Oil)	PROAIR-52
7	Isolation Valve	DV-8000035
8	Activated Carbon Filter	PROAIR-53
9	Filter Kit (Includes Items 2, 6, 8)	PROAIR-63

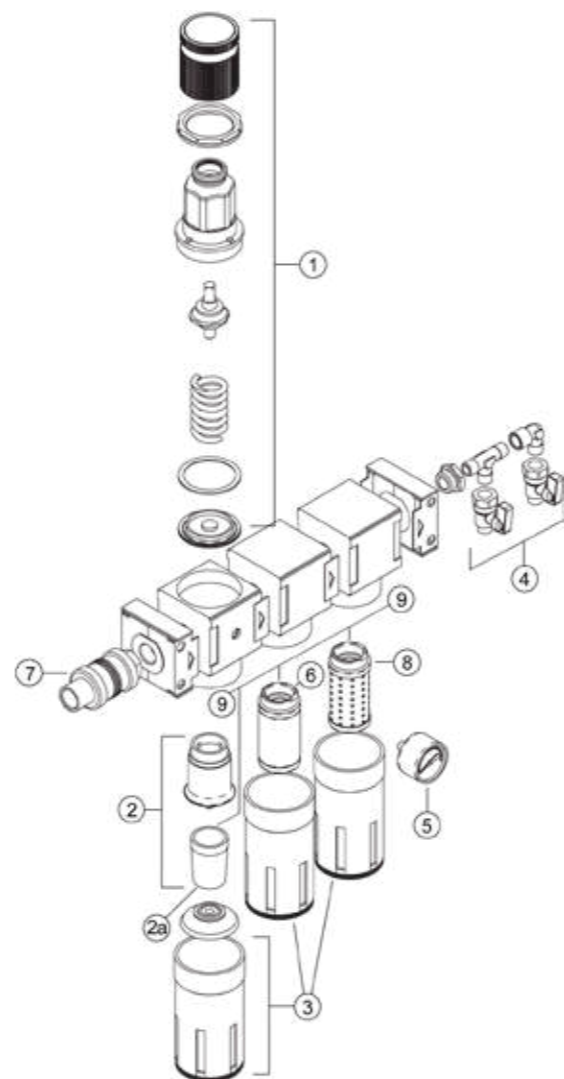

**PRO AIR-4
FILTER
REGULATOR
COALESCER**

ProAIR-4 DeVilbiss
By Binks

PRO AIR - 4



PRODUCT
+
**The unit has a
generous capacity
of 90 cfm.**

- For conventional and compliant spray guns.
- Provides air filtration to a particle size of 5 microns.
- The unit has a generous capacity of 90 cfm.

SPECIFICATIONS

Air Inlet Thread:	1/2" BSP female
Regulated Outlets	2 Valved + 1 Plugged
Unregulated Outlets	1 Valved + 1 Plugged
Air Outlets (Ball Valves)	1/ 4" BSP (M)
Width (Overall)	290mm (11.5")
Height (Overall)	280mm (11")
Weight	2950 gms (104 oz)
Capacity (maximum air flow)	2550 l/min (90 cfm)
Maximum Air Inlet Pressure	13 bar (189 psi)
Maximum Regulated Outlet Pressure	0-8 bar (0-116 psi)
Maximum Operating Temperature	80°C (176°F)
Pressure Gauge	0-11 bar (0-160 psi)
Gauge port	1/8" BSP (F)
Air Filtration	Down to 5 microns
Drain Valve	Semi-Automatic
Maximum Pressure Drop	5% of Inlet Pressure

*Not suitable for use in low bake spray booths.

PRO AIR-4 REGULATOR

Part No	Description
PROAIR-4	3 Outlet Filter Regulator Coalescer (1 filtered, 2 filter regulated)
DV-9420601	Filter bowl removal tool

Ref No	Description	Part No
1	Upper Cover Assembly	PROAIR-71
2	Filter (Air)	PROAIR-51
2a	Filter Element Only	-
3	Metal Filter Bowl	PROAIR-72
4	Ball Valve	SER-3414-MF
5	Pressure Gauge	GA-319

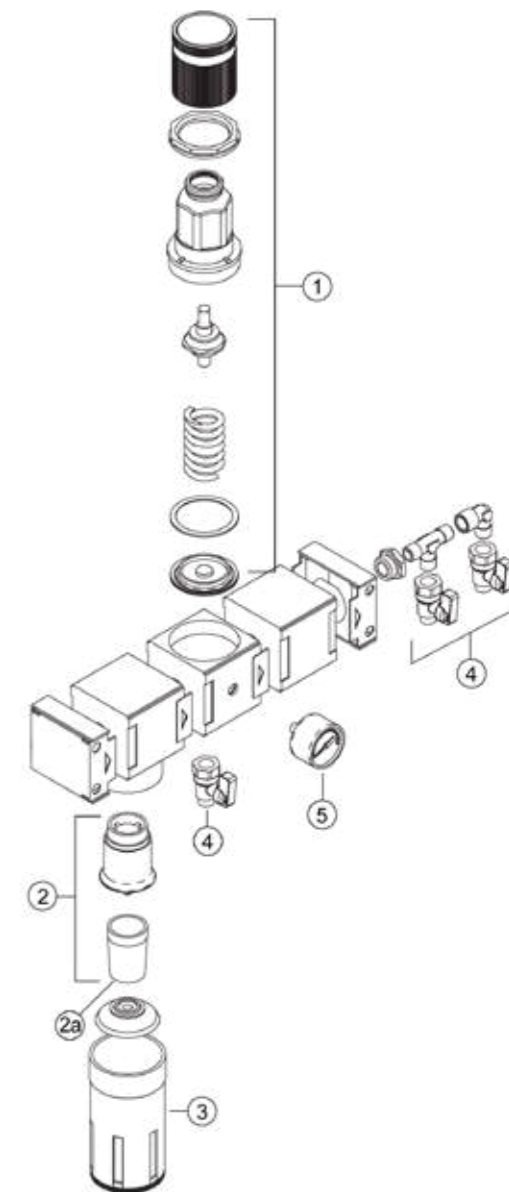

ECONOMY REGULATORS

FLFR-1 FILTER REGULATOR

- Air filtration down to 20 microns.
- High quality manufacture.
- Air flow of 70cfm (at 7 bar – 100 psi inlet pressure).
- Lockable and removable (tamperproof) control



FLCF-1 COALESCING FILTER

- A 3/8" (port size) coalescing (fine oil) filter.
- Air filtration down to 0.01 microns.
- Replaceable filter element.
- Maximum working pressure 18 bar (260 psi).



FLRC-1 – FILTER REGULATOR COALESCER

- Compact, low cost single operator Filter Regulator and Coalescer.
- Filtration down to 0.01 microns suitable for air mask or visor.



FLRCAC-1 FILTER REGULATOR COALESCER WITH ACTIVATED CARBON FILTER

- High efficiency filter designed to remove dirt, liquid oil and water from spraying and breathing air.
- Filtration down to 0.01 microns plus activated carbon filter removing contaminants down to 0.003 microns.



REGULATOR ASSEMBLIES

Part No	Description
FLFR-1	Single outlet Filter Regulator (70cfm)
FLCF-1	Coalescing (fine oil) filter (25cfm)
FLRC-1	Single outlet Filter Regulator Coalescer
FLRCAC-1	Single outlet filter regulator coalescer with activated carbon filter
XA-12	Replacement coalescing filter element (FLRC + FLRCAC)

AC-12	Replacement activated carbon filter (FLRCAC)
9450802	Upper Cover (All)
9450301	Metal Bowl (All)
GA-319	Gauge (FLFR+ FLRC+ FLRCAC)
9450102	Replacement filter element (FLFR, FLRC, FLRCAC)

PAINT CUPS

GRAVITY FEED CUPS

Par No	Description
GFC-501	568ml (1 Pint) Acetal gravity cup for GTi Pro, GTi Pro LITE, GFG & GPi
905359	Gravity Cup Aluminium II
KGP-509-1	284ml (1/2 Pint) Nylon gravity cup for GFG
SRI-510	125ml Acetal gravity cup for SRI Pro LITE
GFC-515	568ml (1 pint) black UV gravity cup. Compatible with DV1
SRI-42-K3	Pack of 3 cone filters
GFC-402	Lid assembly for GFC-501 gravity cup
KGP-401	Lid assembly for KGP-509 gravity cup
GFC-17-K5	Washer
GFC-2-K5	Pack of 5 drip check lids
KGP-5-K5	Pack of 5 gravity cup strainers for GFC-501 & KGP-509
SRI-8-K6	Pack of 6 lids for SRI gravity cups
KR-459-K5	Mini cups
GFC-404-K2	Disposable Lid Kit (GFC-502)
SLG-450	Gravity Cup for SLG-610/620



SUCTION FEED CUPS

Par No	Description
905353	1 litre standard suction cup and lid assembly for
906358	Cup only – 1 litre suction cup
905357	Suction cup lid assembly for JGA cups
905355	Pack of 5 drip free diaphragms
905354	Pack of 3 Tri-Seal gaskets for KR suction cups
KR-566-1-B	Cup 1L suction drip free
KR-466-K	Cup only 1L suction feed
KR-4001-B	Cup lid assembly suction
KR-115-K5	Diaphragms kit of 5
KR-11-K3	Cup gaskets kit of 3
KR-69-K3	Pack of 3 Leather gaskets for suction cups
KR-483-K10	Kit of 10 mesh KR cup strainers – to fit 7/16" tube, 115 Micron
KR-484-K10	Kit of 10 mesh KR cup strainers – to fit 7/16" tube, 350 Micron



HOSES

- High Flow Air Hose with Connections.
- High air flow, high quality rubber air hose.
- 8mm (5/16") bore ideal for use with conventional, compliant / HVLP spray guns, air fed breathing equipment and other air tools.



Option 1
10 metre length air hose complete with quality chrome replaceable 1/4" swivel nut female fittings either end.
Part No: H-6065



Option 2
10 metre length air hose complete with crimped female quick detach connection at one end and crimped male QD fitting at the other end.
Part No: H-6085-QD



Option 3
10 metre length air hose complete with crimped female quick detach connection at one end and crimped female loose nut fitting at the other end.
Part No: H-6086

HIGH FLOW AIR HOSE ASSEMBLIES

Red rubber air hose assemblies including 1/4" BSP connections



Par No	Description
H-7501HA-1.2	1.2 metre, 5/16" ID Air Hose Assembly - For KBII
H-7501HA-5	5 metre, 5/16" ID Air Hose Assembly
H-7501HA-7.5	7.5 metre - 5/16" ID Air Hose Assembly

Par No	Description
H-7501HA-10	10 metre - 5/16" ID Air Hose Assembly
H-7501HA-15	15 metre - 5/16" ID Air Hose Assembly
H-7502HA-7.5	7.5 metre - 3/8" ID Air Hose Assembly
H-7502HA-10	10 metre - 3/8" ID Air Hose Assembly
H-7502HA-15	15 metre - 3/8" ID Air Hose Assembly

Air Hose Connections

- Part No: P-HC-4527** 1/4" BSP Female (8mm (5/16") hose bore)
Part No: P-HC-4528 1/4" BSP Female (9.5mm (3/8") hose bore)

FLUID HOSE ASSEMBLIES

Black rubber fluid hose assemblies including 3/8" BSP connections



Par No	Description
H-7503HA-1.45	1.45 metre 1/4" ID Fluid Hose Assembly - For KBII
H-7503HA-5	5 metre 1/4" ID Fluid Hose Assembly
H-7503HA-7.5	7.5 metre 1/4" ID Fluid Hose Assembly

Par No	Description
H-7503HA-10	10 metre 1/4" ID Fluid Hose Assembly
H-7503HA-15	15 metre 1/4" ID Fluid Hose Assembly
H-7504HA-5	5 metre 3/8" ID Fluid Hose Assembly
H-7504HA-10	10 metre 3/8" ID Fluid Hose Assembly
H-7504HA-15	15 metre 3/8" ID Fluid Hose Assembly

Fluid Hose Connections

- Part No: P-HC-4543** 3/8" BSP Female (6mm (1/4") hose bore)
Part No: P-HC-4548 3/8" BSP Female (9.5mm (3/8") hose bore)

QUICK DETACH FITTINGS

- High flow connections - minimal pressure drops
- Ideal for spray guns, respirators, hoses and regulators

- MPV-5** - Male quick detach stem with 1/4" female fitting:
MPV-424 - Female quick detach connection with 1/4" male fitting:
MPV-10 - Male quick detach stem with 1/4" male fitting:
MPV-462 - Female quick detach with 1/4" female fitting:
MPV-463 - Economy pack, includes 1 of each shown in the picture to the right:
MPV-60-K3 - Male quick detach Uni Swivel stem with 1/4" female fitting:



MIXING CUPS

- Easy to use, disposable mixing cups
- Made from solvent resistant clear polypropylene
- Calibrated with a 0-600 volumetric measurement scale

Part No: MC-1-K50 Pack of 50 cups
Part No: MC-1-K1000 Pack of 1000 cups

Part No: MC-2-K50 Pack of 50 lids
Part No: MC-2-K1000 Pack of 1000 lids



IN-LINE AIR FILTERS

- Lightweight, gun mounting air filter
- High efficiency action traps water, oil and dirt
- Tough solvent resistant acetal housing with 1/4" threads

Part No: HAF-507



IN-LINE AIR ADJUSTING VALVE

- Fits neatly in-line at the gun air inlet
- Increase or decrease working pressure at the gun
- Calibrated up to 11 Bar (160 psi)

Part No: HAV-501-B



VISCOSITY CUPS

- The fast, simple way to check out paint viscosity
- Tough durable and easy to clean
- Precision metal drain out insert

Part No: 7000-114-K2 Pack of 2 viscosity cups



GUN CLEANING BRUSHES

- Ideal for a variety of gun cleaning jobs
- Tough resilient bristles for useful service
- Suitable size for cleaning most parts of the gun

Part No: 4900-5-1-K3 Pack of 3 brushes



PROFESSIONAL SPRAY GUN CLEANING KIT

- Handy tool wrap style kit of purpose made cleaning brushes and tools
- Includes cleaning instructions and spray gun oil
- Keeps your spray guns in top working order

Part No: KK-4584



SPRAY GUN SERVICE KIT

- Spray gun service/repair kit for GTIPRO and SRIPRO

Part Nos: 905279 - Service kit



GUN LUBE

- Pack of 10 gun lube sachets.

Part No: GL-1-K10



PRODUCT
+
2.3 litres capacity. Greater area coverage, less refills.

- Aluminium or stainless steel options (for waterbase materials).
- Familiar gun grip handle plus belt hook for operator convenience.
- At-the-job controls with lid mounted pressure gauge.
- Available complete with short cup to gun air and fluid hoses.
- KB disposable liners make cleaning and colour changes fast and simple.

SPECIFICATIONS

Air Inlet and outlet connections threads	1/4" BSP (M)
Fluid outlet connection (to spray gun)	3/8" BSP (M)
Maximum working pressure	2.1 Bar (30 psi)
Maximum air supply pressure	8.6 bar (125 psi)
Height	183 mm
Weight (less hoses)	1.76 kg
Cup Capacity	2.3 litres

SPRAY GUN KITS FOR USE WITH KBII

Par No	Description
905145 to 905156	Prolite Pressure High Efficiency Gun Kit
905100 to 905117	Prolite Pressure Conventional Gun Kit

Kit contents are spray gun, (suction cup with filter if appropriate), Torx key, brush and multi-fit spanner
** = Air Cap / *** = Fluid Tip

KBII REMOTE CUP KITS

Par No	Description
KB-522	Aluminium Remote Cup without hoses
KB-522-SS	Stainless Steel Remote Cup without hoses
KB-622	Aluminium Remote Cup complete with air and fluid hoses

ACCESSORIES

Par No	Description
KB-422	Aluminium 2.3 Litre KBII Spare Cup Only for KB-522
KB-442	Stainless Steel 2.3 Litre KBII Spare Cup Only for KB-522-SS
KK-5051	Kit of 20 disposable liners plus lid diaphragms
H-7501HA-1.2	1.2m Air Hose Assembly with BSP Fittings
H-7503HA-1.45	1.45m Fluid Hose Assembly with BSP Fittings
GA-355	Air Pressure Gauge for KBII - 0-30 psi

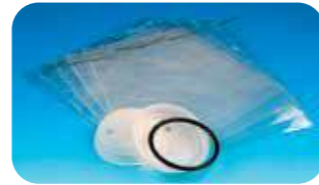

KK-5051



KB-422

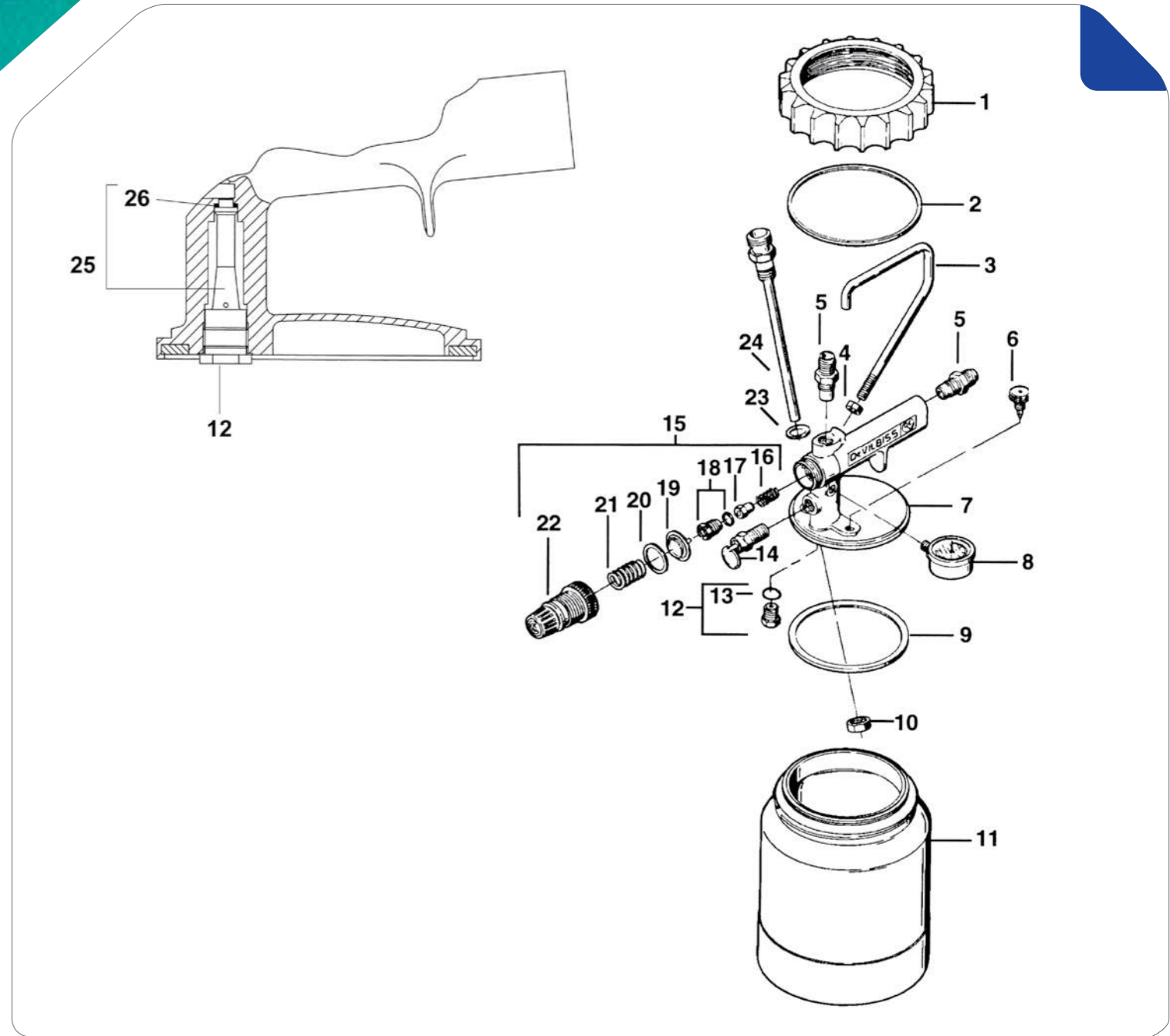

Ref No	Description	Part No
1	Retaining Ring	KB-64
2	Slip Rings	KB-81-K5
3	Handle	KB-74
4	CD Nut	-
5	Connector 1/4" BSP	JGA-158
6	Pressure Relief Valve	KB-66
7	Lid	Not available
8	Gauge	GA-355
9	Seal	KB-80-K5
10	Locknut (KB-522) kit of 5	MBD-11-K5
11	Cup - Aluminium (KB-522)	KB-422
	Cup - Stainless Steel (KB-522-SS)	KB-442
12	Check Valve kit of 3	KB-432-K3
13	Seal kit of 5	KB-85-K5

14	Safety Valve	TIA-4355
15	Regulator Assembly	KB-428-1
16	Spring	-
17	Valve	-
18	Valve Seat and Seal	-
19	Diaphragm	-
20	Slip Ring	-
21	Spring	-
22	Bonnet	-
23	Seal kit of 6	KB-60-K6
	Tube Assembly 3/8" BSP (KB-522-B)	KK-4997
24	Tube Assembly 3/8" BSP STS (KB-522-SS)	KK-4996
25	Check Valve and Seal Assembly	KB-444
26	Seal kit of 5	KB-101-K5

HOSE & FITTINGS

1.2m Air Hose Assembly with BSP Fittings	-H-7501HA-1.2
1.45m Fluid Hose Assembly with BSP Fittings	-H-7503HA-1.45

DX PUMPS

- Acetal pump body with stainless steel balls and soft seats for universal paint compatibility.
- The unique diaphragm design and "built in" fluid regulator provide consistent pressure and readily adjustable paint flow.
- The Non-stall air valve provides smooth, quiet and surge free paint delivery up to 1000 cc/minute.
- Clearly labelled Air regulators provide independent control of pump and spray gun fluid and air pressures.
- Re-circulation/dump valve accessory for faster colour changes reducing down time, saving time and money.
- Pump outfit mountings include Cart, Wall and Tripod outfits with or without spray guns & hoses.

PRODUCT

+
Quick release air, fluid inlet and outlet connections for faster maintenance.



SPECIFICATIONS

Pump Ratio	1 to 1
Max. Air Pressure	7 Bar / 100 psi
Max. Fluid Pressure	7 Bar / 100 psi
Nominal Flow Volume / Cycle	0.07 Litres (0.018 US Gall)
Fluid Output @ 60 cycles/min	4.2 Litres / min (1.1 US Gall / min)
Max Recommended Continuous Cycle Rate	10 Cycles /min
Max Recommended Intermittent Cycle Rate	30 Cycles /min
Inlet Fluid Connection	3/8" Universal (BSPP/NPSM) Male or Female
Outlet Fluid Connection	3/8" Universal (BSPP/NPSM) Male or Female
Maximum Dry/Wet Lift	6.6m (21.8 feet)
Air Inlet	G1/4" (BSPP) Female
Fluid Regulator Pilot	Ø4 Tube
Air Volume / cycle @ 6.9Bar/100 psi	0.77L (0.027SCFM)
Air Flow @ 10 cycles/min 6.9 bar/100 psi	7.7L/min (0.27SCFM/min)
Air Flow @ 30 cycles/min 6.9 bar/100 psi	23.2L/min (0.82SCFM/min)
Air Quality ISO 8573.1 Class 3.3.2 #	Dirt 5 microns Water -20°C @ 7bar (940ppm) Oil 0.1mg/m3 Non Lubricated
Noise Level	68db LAeq
Earth (Air Inlet Cover)	<1Ω
Weight – Bare Pump	2.2 Kg (4.9 lbs)



SPRAY GUN KITS FOR USE WITH THE DX PUMP

Par No	Description
905145 to 905156	Prolite Pressure High Efficiency Gun Kit

DX PUMP OUTFITS

Par No	Description
DX70R3-CF2	Cart mounted pump outfit with filter and three air controls
DX70R3-TF2	Tripod mounted pump outfit with paint filter and three air controls
DX70R3-WF2	Wall mounted pump with paint filter and three air controls

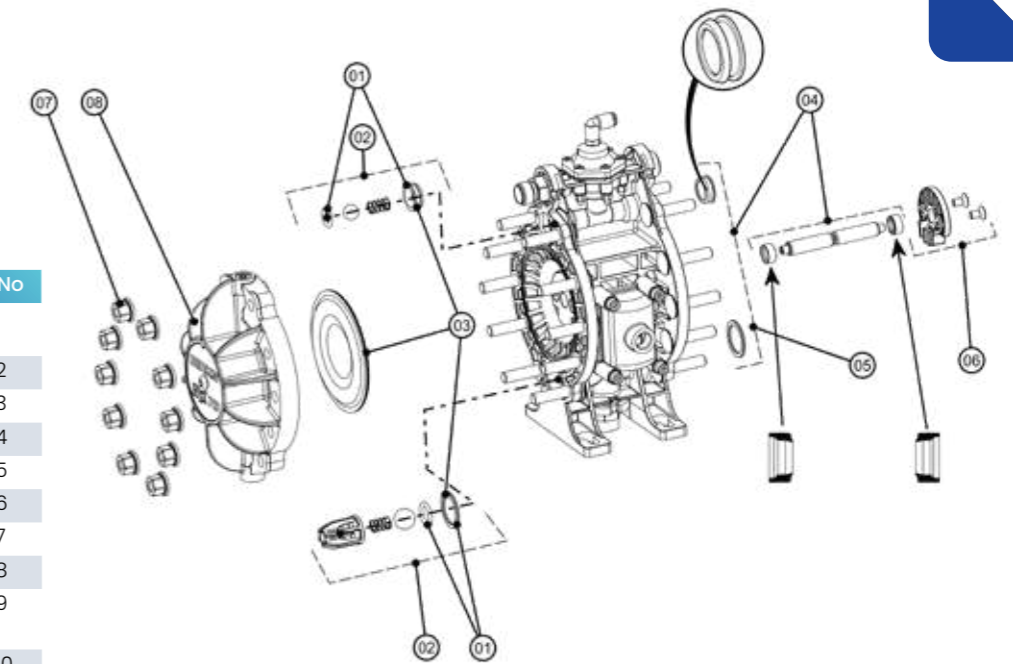

Ref No	Description	Part No
1	Check valve seal kit x4	DXK-1
2	Check valve kit x4	DXK-2
3	Diaphragm kit x2	DXK-3
4	Shaft & seal kit	DXK-4
5	End cap seal kit x2	DXK-5
6	Caps & screws x2	DXK-6
7	End cap nut x10	DXK-7
8	End Cap	DXK-8
9	Inlet, outlet & plug connector seal kit	DXK-9
10	Male inlet connector kit	DXK-10

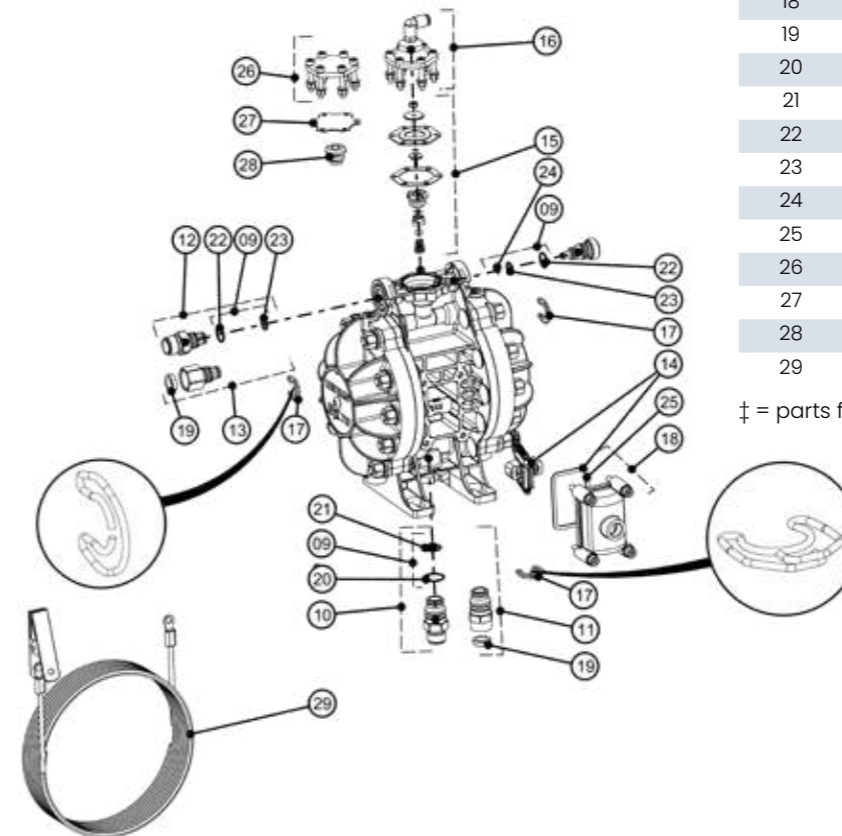

Ref No	Description	Part No
11	Female inlet connector kit	DXK-11
12	Male outlet connector kit	DXK-12
13	Female outlet connector kit	DXK-13
14	Air valve kit	DXK-14
15	Fluid regulator kit	DXK-15
16	Regulator cap & screws	DXK-16
17	Inlet (x2) & outlet (x2) clips	DXK-17
18	Cover, seal & screws	DXK-18
19	Female inlet / outlet thread seal x4	DXK-19
20	O-ring x5	DXK-20
21	O-ring x5	DXK-21
22	O-ring x5	DXK-22
23	O-ring x5	DXK-23
24	O-ring x5	DXK-24
25	Gasket x4	DXK-25
26	Blanking plate & screws ‡	DXK-26
27	Blanking gasket x 4 ‡	DXK-27
28	Insert ‡	DXK-28
29	Grounding cable 4m	0114-011798

‡ = parts for non-fluid regulator model

MXL PUMPS

- Patented air valve technology. Enables pump to change over quickly to significantly reduce pulsation.
- Long lasting ceramic coated piston rods. Superior wear resistance lasting up to three times longer than hard chrome pistons.
- Designed to pump long with less downtime and extended packing life. Self-adjusting sprint loaded fixed packings last up to three times longer than the competition. Large sight glass for visual packing inspection.
- Air Assisted Airless HVLP Spray Gun provides the latest atomisation technology.
- Stainless Steel system – pump and gun.



- Lightweight Air Assisted Airless Gun.
- High quality atomization for industry leading finish.
- Solid forged gun body for maximum durability and longer life.
- Quick-Clean™ gun coating for fast cleaning and maintenance
- Wide selection of flat, fine-finish and twist tips available.



Par No	Description
MXL432PU-C-F-ACG	Cart Mounted (Trophy AA4400 gun not included)
MXL432PU-T-FG-ACG	Tripod Mounted (Trophy AA4400 gun not included)
4400-HI0000	Trophy AA4400 with AA10 HVLP air cap, without flat tip

PUMP SPECIFICATIONS

Ratio	32:1
Max Inlet Pressure	8.0 bar (116 psi)
Flow Rate Nominal	1.4 l/min
Flow Rate Max	4.0 l/min
Volume/Cycle	24cm ³
Max Operating Pressure	256 bar (3600 psi)
Cylinder Diameter	85 mm
Piston Stroke	75 mm
Air Consumption @ 20 cycles/min	147 l/min

GUN SPECIFICATIONS

Maximum fluid pressure	303 Bar (4,400 psi)
Maximum air inlet pressure	7 bar [105 psi]
Gun body material	Forged Aluminium
Fluid path material	Stainless Steel
Fluid seat Material	Tungsten Carbide
Fluid inlet connection	1/4" NPS (m)
Air inlet connection	1/4" BSP / NPS (m)

ACCESSORIES

Par No	Description
0110-009132	Filter insert for high pressure filter - 100 mesh
0110-009133	Filter insert for high pressure filter - 150 mesh
0110-009134	Filter insert for high pressure filter - 200 mesh

FOR A DETAILED BREAKDOWN OF THE MXL PUMPS PLEASE CONSULT YOUR SERVICE BULLETIN OR CONTACT THE DEVILBISS CUSTOMER SERVICE DEPARTMENT.

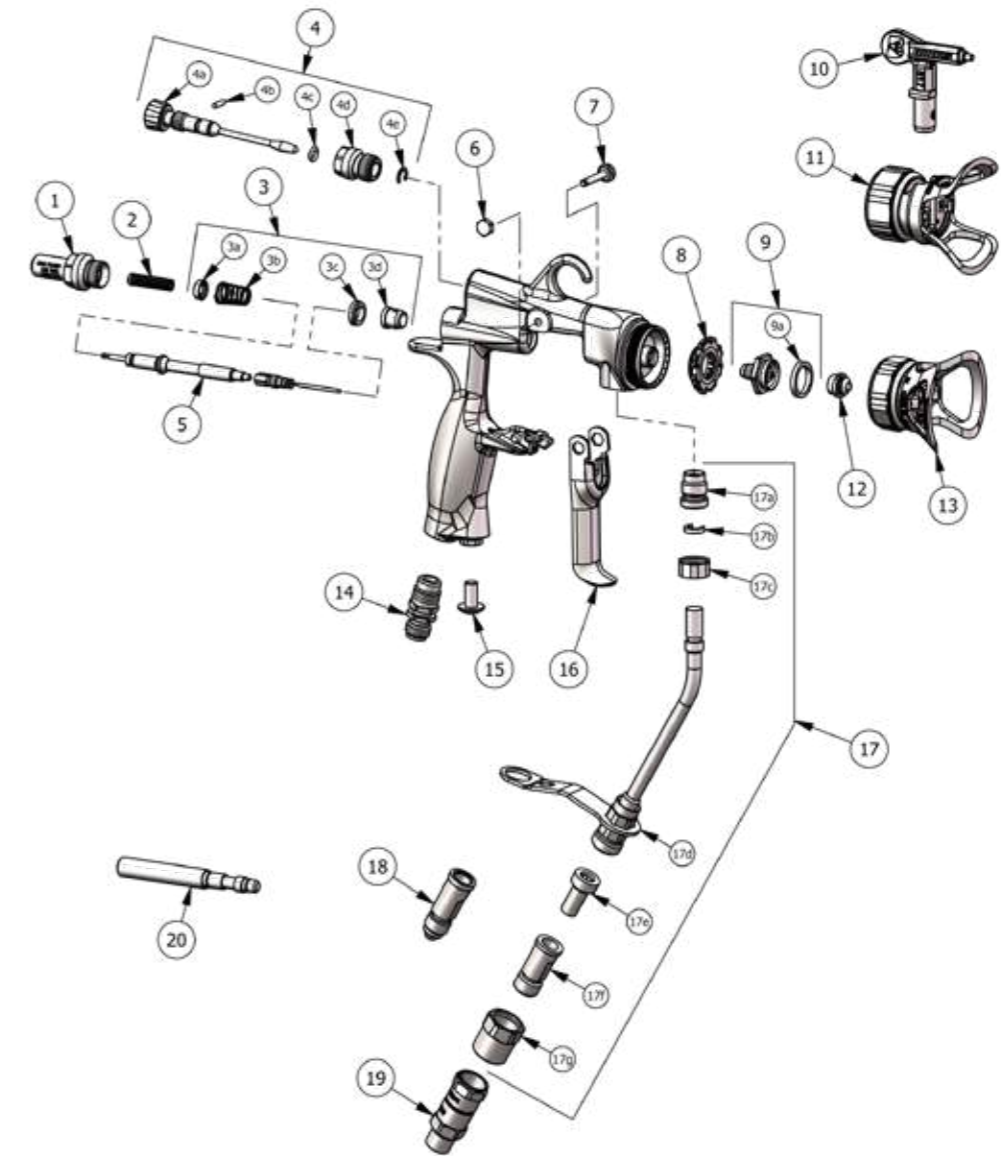

Ref No	Description	Part No
1	Air valve housing	54-6007
2	Needle return spring kit (multi-pack)	54-5935-K5
3	Spindle seal & spring kit	54-6131-K
3a	Rear seal	-
3b	Air valve spring	-
3c	Valve seal	-
3d	Front seal	-
4	Spreader valve assembly	54-5815
4a	Valve stem	-
4b	Pin	-
4c	O-ring (multi-pack)	SN-71X-K2
4d	Valve body	-
4e	Snap ring	-
5	Air valve & fluid needle assembly	54-5937
6	Trigger nut	54-6114
7	Trigger Screw	54-6115
8	Baffle plate (multi-pack)	SPA-71-K5 SPA-71-K10
9	Fluid nozzle & gasket (flat tip)	54-5811-K
	Fluid nozzle & gasket (twist tip)	54-5833-K

9a	Gasket (multi-pack)	SPA-98-K5 SPA-98-K10
10	Reversible twist tip	-
11	HVLP twist tip air cap assembly	54-5924-K
12	Flat tip assembly	-
	Fine finish flat tip assembly	-
13	AA10+ air cap assembly	54-6030-K
14	Air inlet (multi-pack)	SN-9-K3
15	Slotted round head screw, 1/4" - 20 x 1/2"	-
16	Trigger	54-6019
17	Fluid tube assembly	54-6015
17a	Fluid tube adapter	-
17b	Fluid tube retainer (multi-pack)	54-5896-K5
17c	Ferrule nut	54-5899
17d	Filter bracket	54-6017
17e	Fluid filter, 100 mesh	54-1835
17f	Disc filter body, 1/4" nps (m)	54-4726-K
17g	Disk filter retainer	-
18	JIC #5 fluid inlet fitting (sold separately)	54-5897
19	Swivel adapter, 1/4" nps m x f (sold separately)	72-2360
20	Tool	SPN-7

- Single regulator and gauge to control tank and air pressure.
- Zinc plated lid assemblies for solvent based coatings.
- Positive four point lid clamping for secure operation.
- High density polyethylene, tank liners ensure efficient use.

PRODUCT
+
Zinc plated tank shell for long service life



SPECIFICATIONS

Tank Capacity	9.5 litre
Maximum working Pressure	5.5 bar (80 psi)
Safety Valve Set Pressure	5.5 bar (80 psi)
Air Inlet Size	1/4" BSP (M)
Fluid Outlet Size	3/8" BSP (M)
Tank Shell	SA-620 H.R Steel Zinc plate 2.7mm (8 gauge)
Tank Lid	SA-414 H.R Steel Zinc plate 4.2mm (3/16")
Fluid Tube	Steel, Galvanised Zinc Plate
Air Manifold	CRS Zinc Plated
Fluid Outlet	Steel, Galvanised Zinc Plate
Lid Gasket	Santoprene™

SPRAY GUN KITS FOR USE WITH KBII

Par No	Description
905145 to 905156	Filter insert for high pressure filter - 100 mesh
905100 to 905117	Filter insert for high pressure filter - 150 mesh

Kit contents are spray gun, (suction cup with filter if appropriate), Torx key, brush and multi-fit spanner

** = Air Cap / *** = Fluid Tip



PT-78-K10



Air Hose



Fluid Hose

PRESSURE FEED TANK

Par No	Description
83C-210-B	9.5 litre capacity zinc plated tank and lid assembly
PT-78-K10	Kit of 10 polyethylene inner liners for 9.5 litre capacity tank
VS-522	Paint filter (100 mesh) and housing - fits directly onto fluid outlet of tank - BSP
H-7501HA-10	10 metre - 5/16"ID Air Hose Assembly
H-7502HA-10	10 metre - 3/8"ID Air Hose Assembly
H-7503HA-10	10 metre - 1/4"ID Fluid Hose Assembly
H-7504HA-10	10 metre - 3/8"ID Fluid Hose Assembly

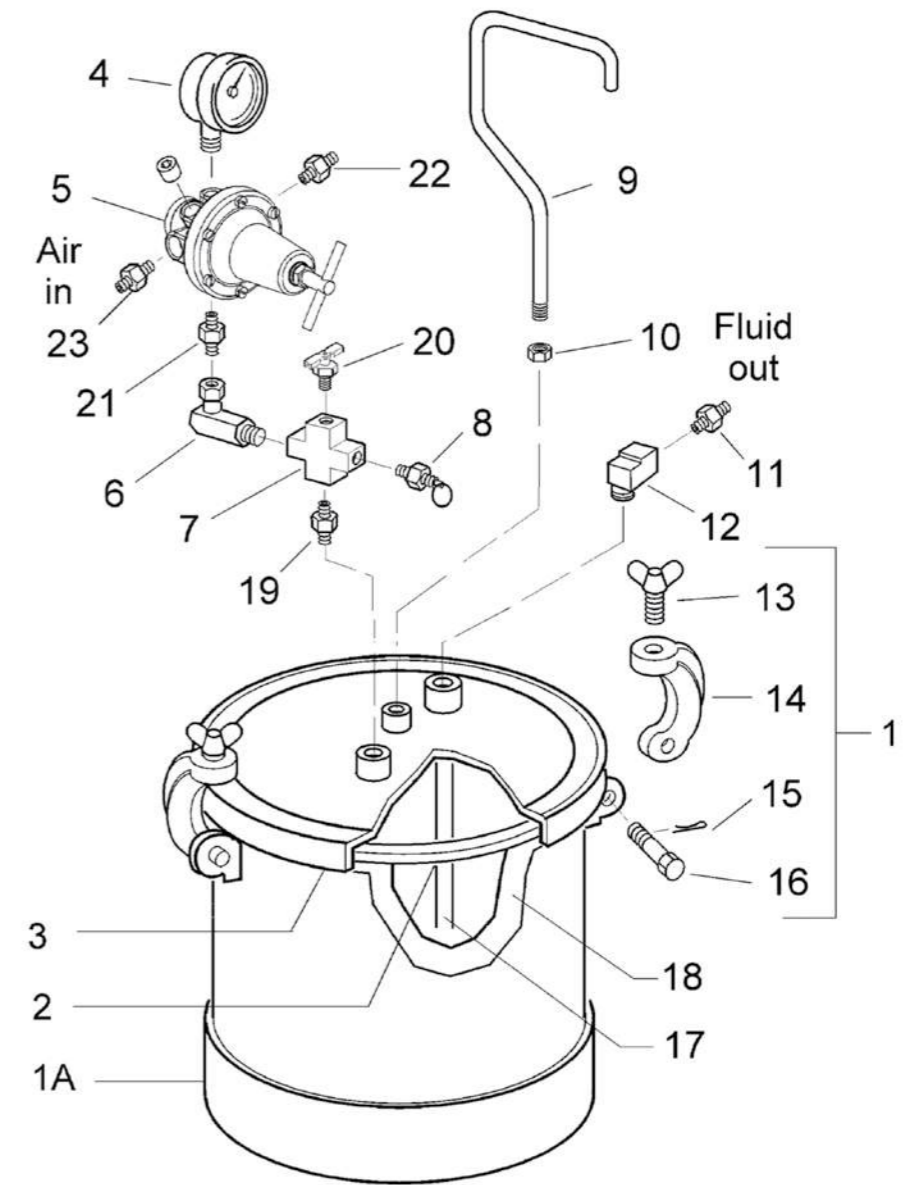

Ref No	Description	Part No
1	Tank Assembly Kit (Includes Ref Nos. 1A, 13, 14, 15 & 16)	-
1A	Tank Shell	-
2	Lid Gasket, Santoprene	PT-33-1
3	Lid, Zinc Plated	-
4	Gauge	83-2727
5	Regulator	HAR-511
6	90° Swivel Adaptor 1/4" NPS (F) x 1/4" NPT (M)	SSP-30-ZN
7	Cross 1/4" NPT (F)	-
8	Safety Valve - 80 psi	TIA-5080-CE
9	Handle	PT-32
10	Hex Nut 3/8" - 16	-
11	Nipple 3/8" NPT (M) x 3/8" NPT (M)	AD-11
	Nipple 3/8" NPT (M) x 3/8" BSP (M)	2101007
12	Street Elbow 3/8" NPT (F) x 3/8" (M) S.S	SSP-1939

13	Thumb Screw	-
14	Yoke Assembly	-
15	Cotter Pin, 3/32 x 1"	-
16	Hinge Pin	-
17	Fluid Tube	PT-31
18	Tank Liner (Kit of 10)	PT-78-K10
	Tank Liner (Kit of 60)	PT-78-K60
19	Hex Nipple 1/4" NPT (M)	-
20	Air Relief Valve	SS-2707
21	D.M Nipple	83-4233
22	(NPS) Nipple 1/4" NPT (M) x 1/4" NPS (M)	H-2008
	(BSP) Nipple 1/4" NPT (M) x 1/4" BSP (M)	2101004
23	(NPS) Nipple 3/8" NPT (M) x 1/4" NPS (M)	83-4233
	(BSP) Nipple 3/8" NPT (M) x 1/4" BSP (M)	2101005

DVFR-1 - FILTER REGULATOR

Par No	Description
DV-9420601	Filter bowl removal tool

Ref No	Description	Part No
1	Upper Cover Assembly	DV-9450806
2	Filter (Air)	DV-9451705
3	Metal Filter Bowl	DV-9453301-MET
4	Ball Valve	SER-3414-MF
5	Pressure Gauge	GA-319
6	Isolation Valve	DV-8000035

DVFR-2 FILTER - REGULATOR COALESCER

Par No	Description
DV-9420601	Filter bowl removal tool

Ref No	Description	Part No
1	Upper Cover Assembly	DV-9450806
2	Filter (Air)	DV-9451705
3	Metal Filter Bowl	DV-9453301-MET
4	Ball Valve	SER-3414-MF
5	Pressure Gauge	GA-319
6	Fine Filter (Oil)	DV-9451711
7	Isolation Valve	DV-8000035

DVFR-3 FILTER REGULATOR

Ref No	Description	Part No
1	Upper Cover Assembly	DV-9350811
2	Filter	9351706
3	Metal Filter Bowl	DV-9353301
4	Ball Valve	SER-3414-MF
5	Pressure Gauge	GA-319

DVFR-8 FILTER REGULATOR COALESCER WITH ACTIVATED CARBON FILTER

Par No	Description
DV-9420601	Filter bowl removal tool

Ref No	Description	Part No
1	Upper Cover Assembly	DV-9450806
2	Filter (Air)	DV-9451705
3	Metal Filter Bowl	DV-9453301-MET
4	Ball Valve	SER-3414-MF
5	Pressure Gauge	GA-319
6	Fine Filter (Oil)	DV-9451711
7	Isolation Valve	DV-8000035
8	Activated Carbon Filter	DV-9451711AC

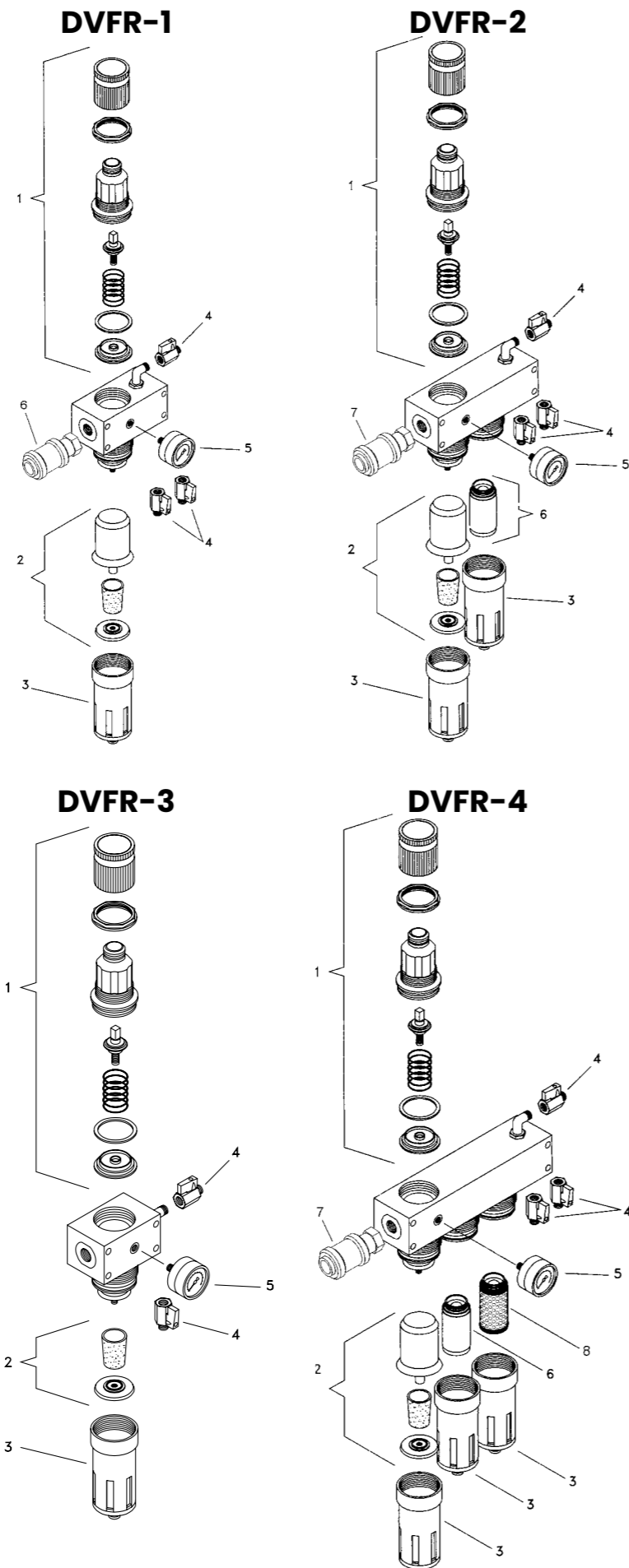

IDEAL FOR:

- Paint and lacquer runs.
- Imperfections.
- Minimising area when sanding paint-filled chips or scratches.

ADVANTAGES:

- Stainless steel 304 provides hardness for re-use.
- Chemically etched shapes eliminates burred edges.
- Choice of four stencil shapes.

SPECIFICATIONS

Dimensions	H: 100 mm D: 90 mm W: 1 mm
Weight	13g each

SHIM MASK

Par No	Description
SHIM-3	Pack of three stainless steel shim masks



PROL-455-****-** Air cap, fluid tip and needle kit (Part 7, 2 & 4)

Kit Part No.	Air Cap	Fluid Tip
PROL-455-	HV25	
	HV30	12
	TE10	13
	TE20	14
	T110	

PRO-470 REPAIR KIT INCLUDES:

Packing, Spring & Packing Nut SN-404

Trigger Stud & Screw*

Spray Head Seal SN-18-1

Seal and Pin Kit GTI-428-K5

Needle Spring PRO-472

*Not sold separately

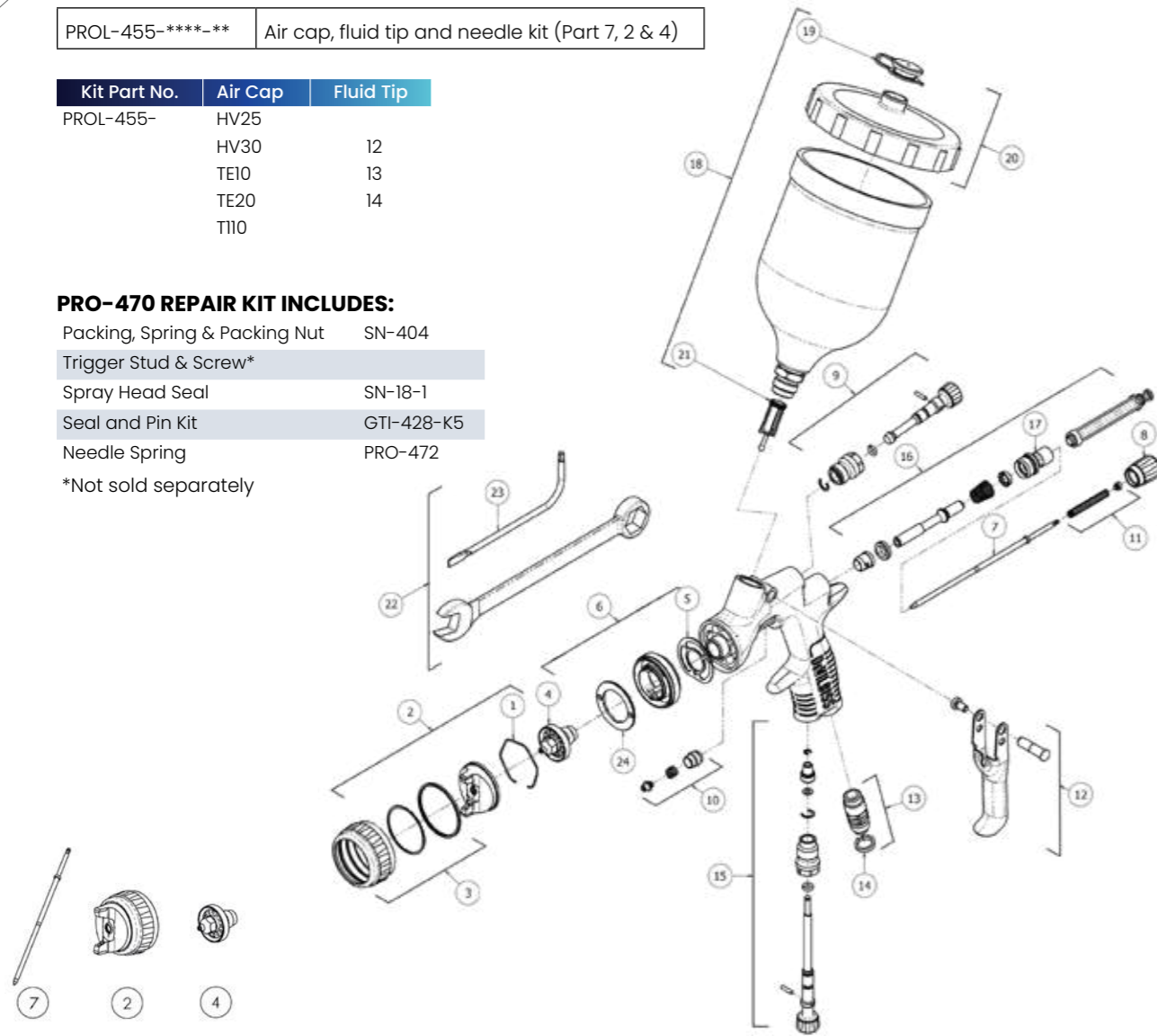

PROGTi-455-****-** Air cap, fluid tip and needle kit (Part 8, 2 & 4)

Kit Part No.	Air Cap	Fluid Tip
ProGTi-455-	HV25	
	HV30	12
	TE10	13
	TE20	14
	T110	

PRO-415-1 REPAIR KIT INCLUDES:

Separator (Kit of 5) SRIPRO-2K

Body Bushing & Seal -

Needle Spring -

Needle Spring Pad -

Spreader Valve Seal -

Packing, Spring & Packing Nut Kit SN-404-K

Trigger Stud Screw (T20 Torx) -

Trigger Stud -

Valve Pin -

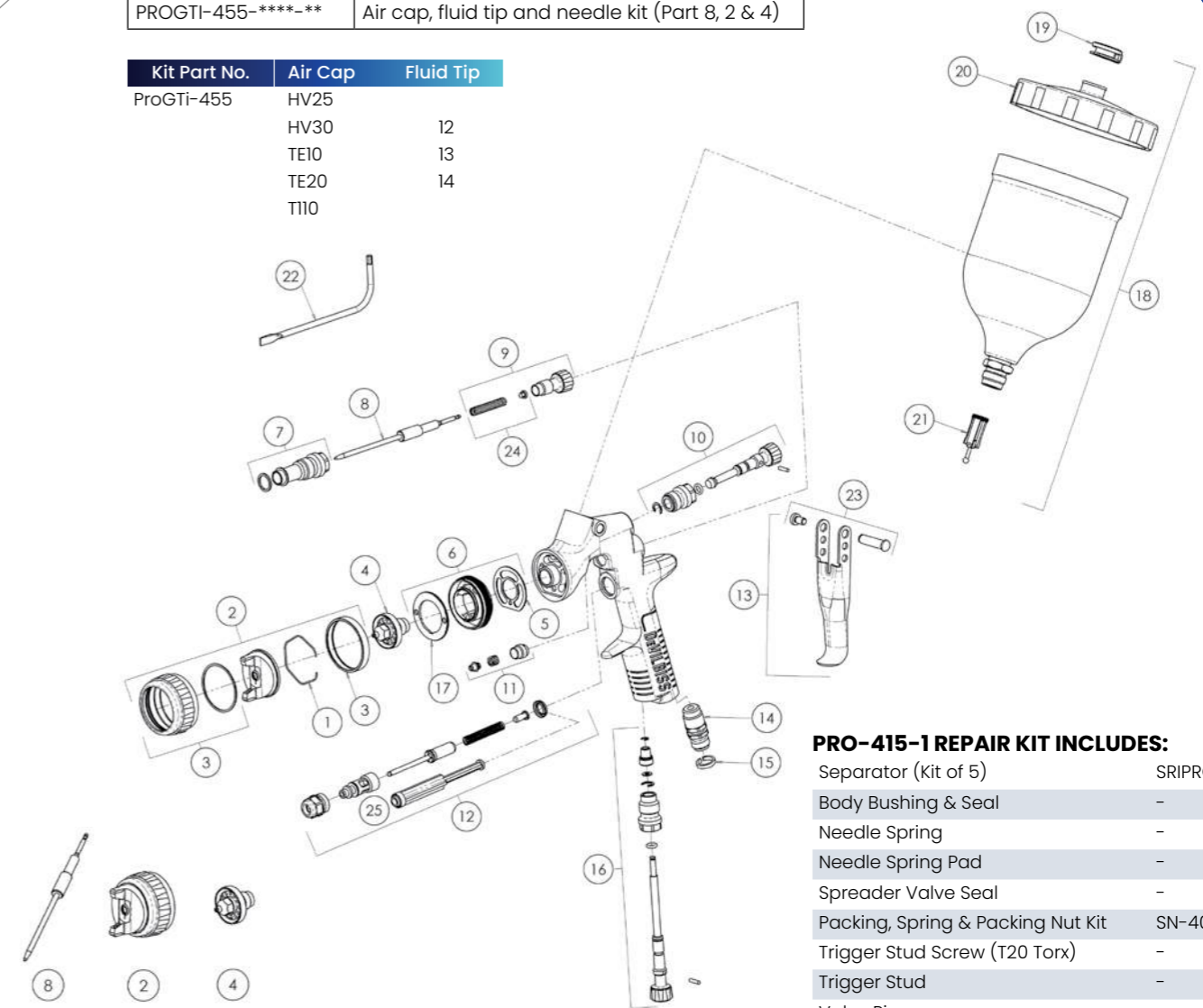

Ref No	Description	Part No
1	Air Cap Retaining Clip	905208
2	TE10 High Efficiency Air Cap & Ring	905240
	TE20 High Efficiency Air Cap & Ring	905241
	HV30 HVLP Air Cap & Ring	905238
	HV25 HVLP Air Cap & Ring	PRO-102-HV25-K
	T110 High Efficiency Air Cap & Ring	905245
3	Air Cap Retaining Ring & Seals	905280
	Cap, tip and needle kit	PROL-455-****-**
4	Fluid Tip 11, 12, 13 or 14	905246/247/248/249
5	Spray Head Seal (kit of 2)	905287
6	Spray Head & Seal Kit	905303
7	Fluid Needle	905266
	Spray gun repair kit	905281
8	Fluid Adjusting Knob	905302
9	Spreader Valve Assembly	905275
10	Packing, Spring & Packing Nut Kit	905294
11	Needle Spring Kit	905283

12	Trigger, Stud & Screw Kit	905306
13	Air Inlet	905305
14	Colour ID Ring Kit (4 Colours)	905289
15	Airflow Valve (Cheater)	905276
16	Air Valve Kit	905282
17	Body Housing	905301
18	Gravity Cup Kit	905204
19	Drip Check Lid (kit of 5)	905202
20	Gravity Cup Lid	905203
21	Filter	905207
22	Torx Key & Spanner	905296
23	Torx Key	905307
24	Baffle Plate	905297
	Boxed digital press gauge for Prolite gravity only	DGI PRO-504-BAR-K
	Swivel QD Stem (pack of 3)	MPV-60-K3
	Disposable whirlwind air filter	HAF-507
	Cleaning brushes kit of 3	4900-5-1-K3

Ref No	Description	Part No
1	Air Cap Retaining Clip	905208
2	TE10 High Efficiency Air Cap & Ring	905240
	TE20 High Efficiency Air Cap & Ring	905241
	HV30 HVLP Air Cap & Ring	905238
	HV25 HVLP Air Cap & Ring	PRO-102-HV25-K
	T110 High Efficiency Air Cap & Ring	905245
3	Air Cap Retaining Ring & Seals	905280
4	Fluid Tips available (1.1 to 2.0)	905246 to 905253
5	Spray Head Seal (kit of 2)	905287
6	Spray Head & Seal Kit	905303
7	Body Bushing & Seal	905300
8	Fluid Needle	PRO-300-K
9	Fluid Adjusting Knob, Spring & Pad Kit	905285
10	Spreader Valve Assembly	905275
11	Packing, Spring & Packing Nut Kit	905294

12	Air Valve Replacement Kit	905293
13	Trigger, Stud & Screw Kit	905288
14	Air Inlet	905305
15	Colour ID Ring Kit (4 Colours)	905289
16	Airflow Valve	905276
17	Baffle plate	905297
18	Gravity Cup Kit	905204
19	Drip Check Lid (kit of 5)	905202
20	Gravity Cup Lid	905203
21	Filter	905207
22	Torx Key	905307
23	Trigger Stud & Torx Screw (kit of 5)	905295
24	Needle spring and pad kit	905291
25	Air valve seal & service tool	905290

PRILT-450-****-** Air cap, fluid tip and needle kit (Part 7, 2 & 4)

Kit Part No.	Air Cap	Fluid Tip
PRILT-450-		14
		16
	PR10	18
		20
		25

PRO-470 REPAIR KIT INCLUDES:

Packing, Spring & Packing Nut	SN-404
Trigger Stud & Screw*	
Spray Head Seal	SN-18-1
Seal and Pin Kit	GTI-428-K5
Needle Spring	PRO-472

*Not sold separately

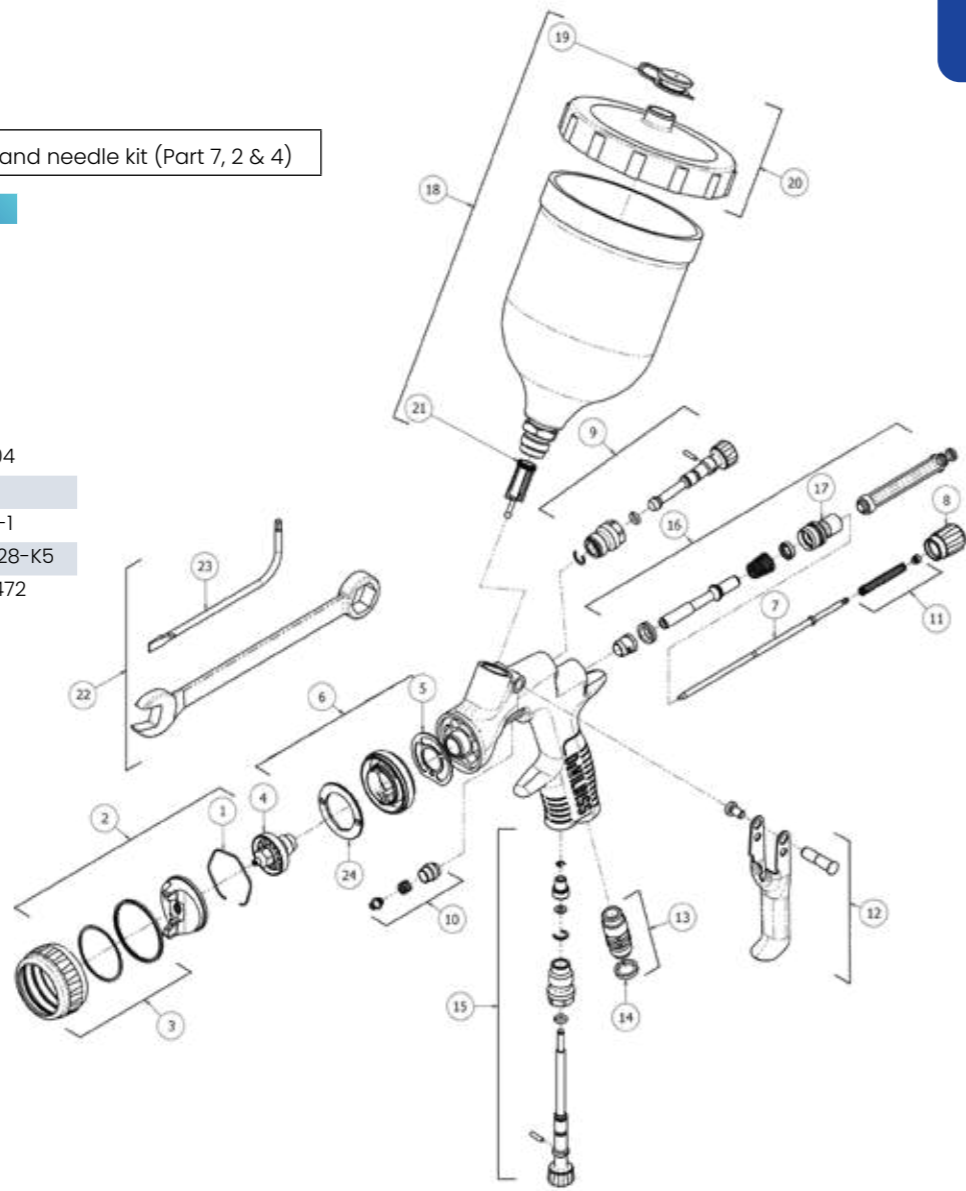

PRILT-450-****-** Air cap, fluid tip and needle kit (Part 4, 1 & 2)

Kit Part No.	Air Cap	Fluid Tip
SRIPROL-450-	MC1	06
	HV5	08
	TE5	10
		12

PRO-415-1 REPAIR KIT INCLUDES:

Separator (Kit of 5)	SRIPRO-2K
Body Bushing & Seal	-
Needle Spring	-
Needle Spring Pad	-
Spreader Valve Seal	-
Packing, Spring & Packing Nut Kit	SN-404-K
Trigger Stud Screw (T20 Torx)	-
Trigger Stud	-
Valve Pin	-

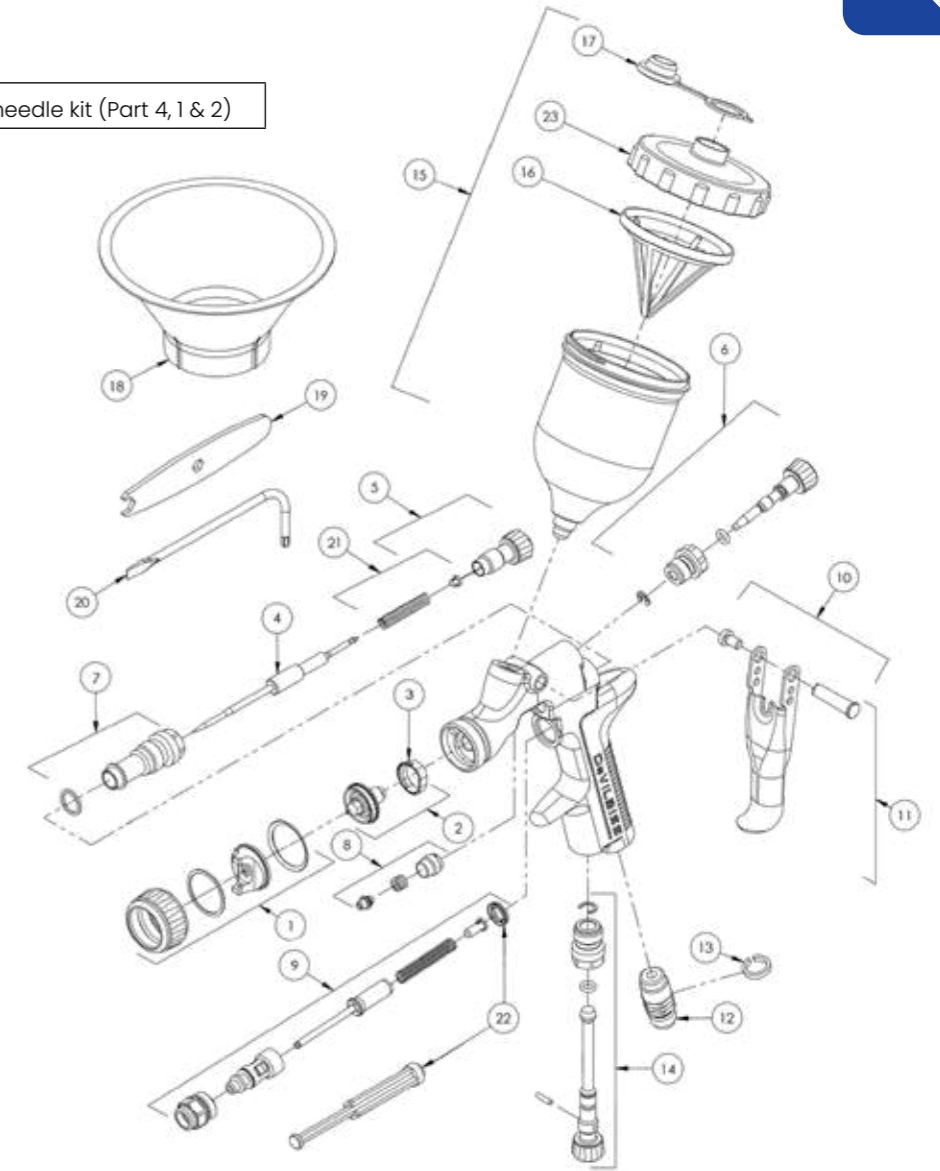

Ref No	Description	Part No
1	Air Cap Retaining Clip	905208
2	High Efficiency Air Cap	PRIPRO-102-PR10-K
3	Air Cap Retaining Ring & Seals	905280
4	Fluid Tip 14,16, 18, 20, 25	PRIPRO-220-**-K
	UV Fluid Tip 1 & 2	905211
5	Spray Head Seal (kit of 2)	905287
6	Spray Head & Seal Kit	905303
7	Fluid Needle	PRIPRO-320-K
	UV Fluid Needle	PRIPRO-319-K
8	Fluid Adjusting Knob, Spring & Pad Kit	905302
9	Spreader Valve Assembly	905275
10	Packing, Spring & Packing Nut Kit	905294
11	Needle Spring Kit	905283
12	Trigger, Stud & Screw Kit	905306

13	Air Inlet	905305
14	Colour ID Ring Kit (4 Colours)	905289
15	Airflow Valve (Cheater)	905276
16	Air Valve Kit	905282
17	Body Housing	905301
18	Gravity Cup Kit	905204
	Black UV Gravity Cup Kit	905205
19	Drip Check Lid (kit of 5)	905202
20	Gravity Cup Lid	905203
21	Filter	905207
22	Torx Key & Spanner	905296
23	Torx Key & Spanner	905307

Ref No	Description	Part No
1	HVLP Air Cap & Ring	905313
	High Efficiency Air Cap & Ring	905316
	Round Spray Air Cap & Ring	905315
	High Efficiency Micro Air Cap & Ring	905314
2	Fluid Tips available (0.8 to 1.40)	905317 to 905320
	Fluid Tip (Micro only)	905321
3	Separator	905322
4	Fluid Needle for No. 08 & No. 10 Fluid Tips	905323
	Fluid Needle for No. 12 & No. 14 Fluid Tips	905324
	Fluid Needle (Micro Only)	905325
5	Fluid Adjusting Knob	905304
6	Spreader Valve Assembly	905326
7	Body Bushing & Seal	905300
8	Packing, Spring & Packing Nut Kit	905294
9	Air Valve Assembly	905293

10	Stud and Screw kit	905295
11	Trigger, Stud & Screw Kit	905298
12	Air Inlet	905292
13	Colour ID Ring Kit (4 Colours)	905289
14	Airflow Valve	905278
15	Gravity Cup Kit	905311
16	Filter	905309
17	Drip Check Lid (kit of 5)	905202
18	Funnel kit of 12	905312
19	Spanner kit of 2	905310
20	Torx Key	905307
21	Needle spring and pad kit	905299
22	Air valve seal & service tool	905290
23	Gravity Cup Lid	905308

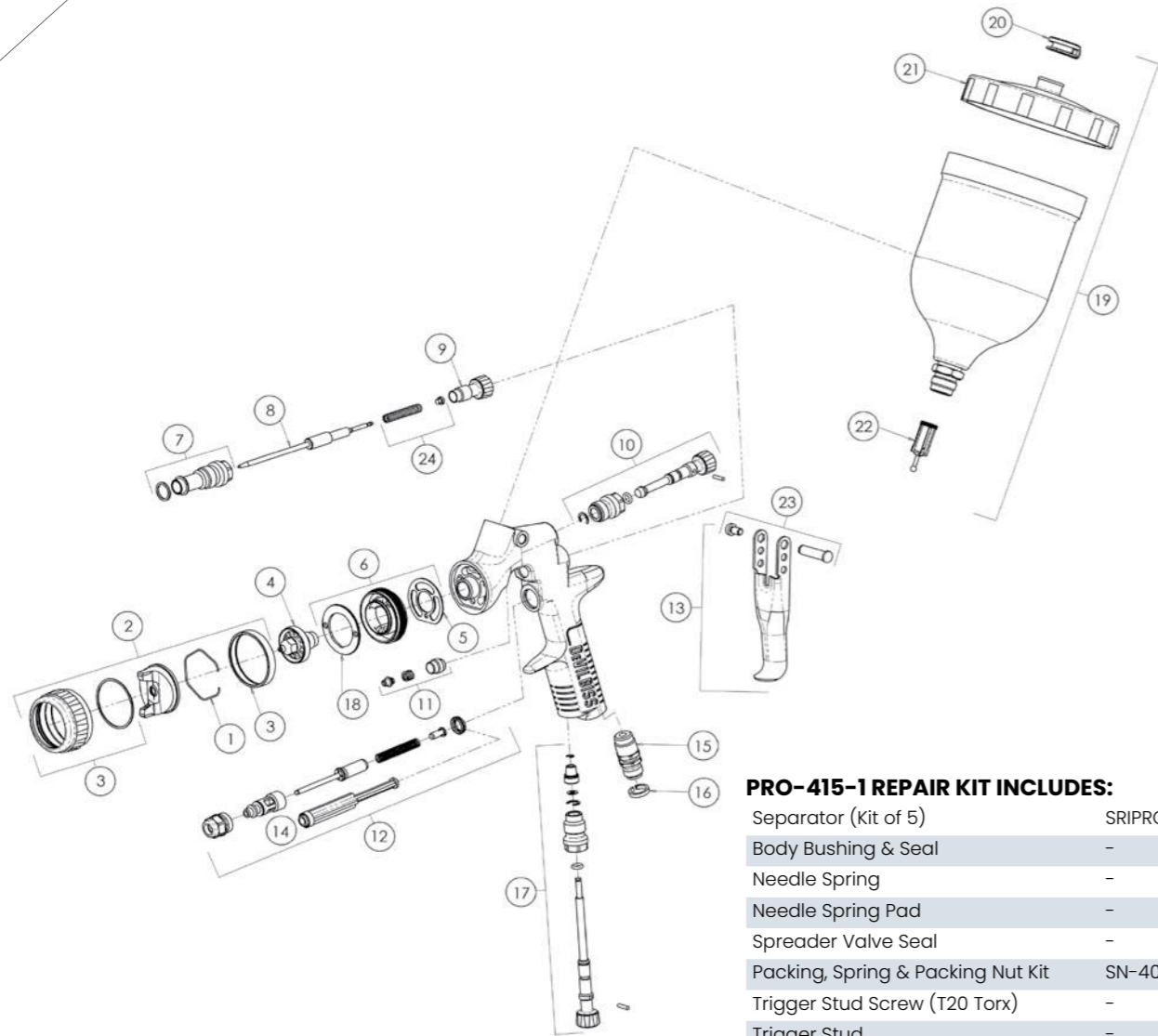

PRO-415-1 REPAIR KIT INCLUDES:

Separator (Kit of 5)	SRIPRO-2K
Body Bushing & Seal	-
Needle Spring	-
Needle Spring Pad	-
Spreader Valve Seal	-
Packing, Spring & Packing Nut Kit	SN-404-K
Trigger Stud Screw (T20 Torx)	-
Trigger Stud	-
Valve Pin	-

Ref No	Description	Part No
1	Air Cap Retaining Clip	905208
2	Air Cap	PRO-102-GPI-K
3	Air Cap Retaining Ring & Seals	PRO-405-K
4	Fluid Tip - 14, 16, 18	PROC-215-**-K
5	Spray Head Seal (kit of 2)	905287
6	Spray Head & Seal Kit	905286
7	Body Bushing & Seal	905300
8	Fluid Needle for No. 14 Fluid Tips	905267
	Fluid Needle for No. 16 & No. 18 Fluid Tips	905268
9	Fluid Adjusting Knob	PRO-3-K
10	Spreader Valve Assembly	905275
11	Packing, Spring & Packing Nut Kit	905294
12	Air Valve Replacement Kit	905293

13	Trigger, Stud & Screw Kit	905288
14	Air Valve Seal & Service Tool	905290
15	Air Inlet	905292
16	Colour ID Ring Kit (4 Colours)	905289
17	Airflow Valve	905276
18	Baffle plate	905297
19	Gravity Cup Kit	905204
20	Drip Check Lid (kit of 5)	905202
21	Gravity Cup Lid	905203
22	Filter	905207
23	Trigger Stud & Torx Screw (kit of 5)	905295
24	Needle spring and pad kit	905291
25	Air valve seal & service tool	905290

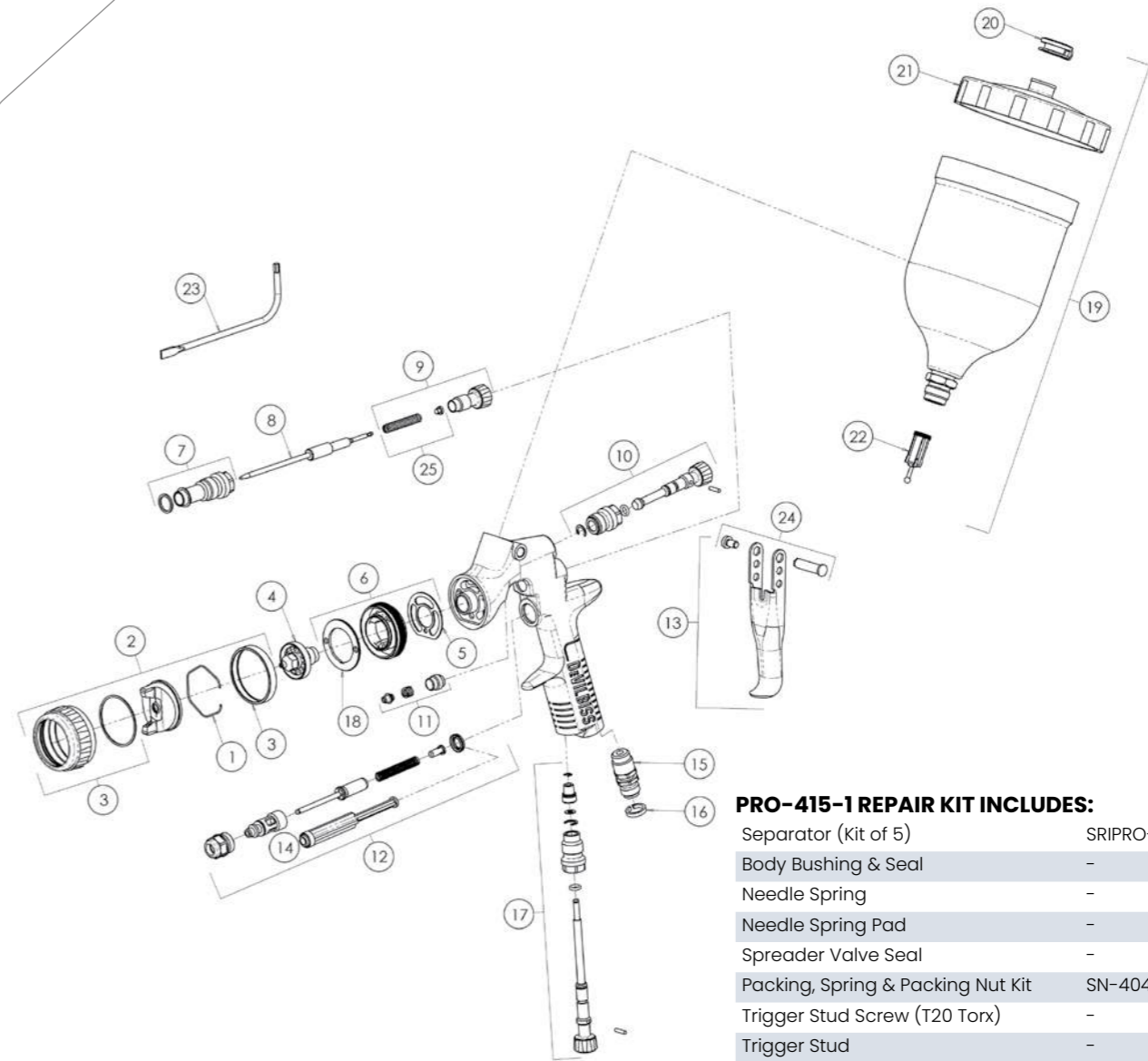

PRO-415-1 REPAIR KIT INCLUDES:

Separator (Kit of 5)	SRIPRO-2K
Body Bushing & Seal	-
Needle Spring	-
Needle Spring Pad	-
Spreader Valve Seal	-
Packing, Spring & Packing Nut Kit	SN-404-K
Trigger Stud Screw (T20 Torx)	-
Trigger Stud	-
Valve Pin	-

Ref No	Description	Part No
1	Air Cap Retaining Clip	905208
2	C1 Aircap & Ring	PROC-120-C1-K
	C2 Aircap & Ring	PROC-120-C2-K
3	Air Cap Retaining Ring & Seals	PRO-405-K
4	Fluid Tip (14, 16 & 18)	PROC-220-**-K
5	Spray Head Seal (kit of 2)	905287
6	Spray Head & Seal Kit	905286
7	Body Bushing & Seal	905300
8	Fluid Needle	GFGPRO-320-K
9	Fluid Adjusting Knob, Spring & Pad Kit	PRO-3-K
10	Spreader Valve Assembly	PRO-402-K
11	Packing, Spring & Packing Nut Kit	905294
12	Air Valve Replacement Kit	905293

13	Trigger, Stud & Screw Kit	905288
14	Air Valve Seal & Service Tool	905290
15	Air Inlet	905292
16	Colour ID Ring Kit (4 Colours)	905289
17	Airflow Valve	PRO-411-K
18	Baffle plate	905297
19	Gravity Cup Kit	905204
20	Drip Check Lid (kit of 5)	905202
21	Gravity Cup Lid	905203
22	Filter	905207
23	Torx Key	905307
24	Trigger Stud & Torx Screw (kit of 5)	905295
25	Needle spring and pad kit	905291

Ref No	Description - Gravity Gun	Part No
1	Retaining ring	905345
2	Air cap	905332
3	Fluid tip 1.4mm	905341
	Fluid tip 1.8mm	905344
	Fluid tip 2.0mm (available separately)	905342
4	Gasket	905352
5	Baffle	*
6	Packing	K-5370
7	U-cup seal	*
8	Air-valve seat	*
9	Air-valve stem	*
10	Air-valve spring	*
11	Fluid needle 1.4mm	905348
	Fluid needle 1.8mm	905349
	Fluid needle 2.0mm (available separately)	905350
12	Filter	905207
13	Lid assembly	905203
14	Drip free vent lid kit of 5	905202
15	Cup assembly	905204
16	Assembly tool	*

- * Seal, baffle and gasket replacement kit, items 4, 5, 6, 7, 8, 9, 10, and 16 905337
- Baffle replacement kit, items 4 and 5 905335

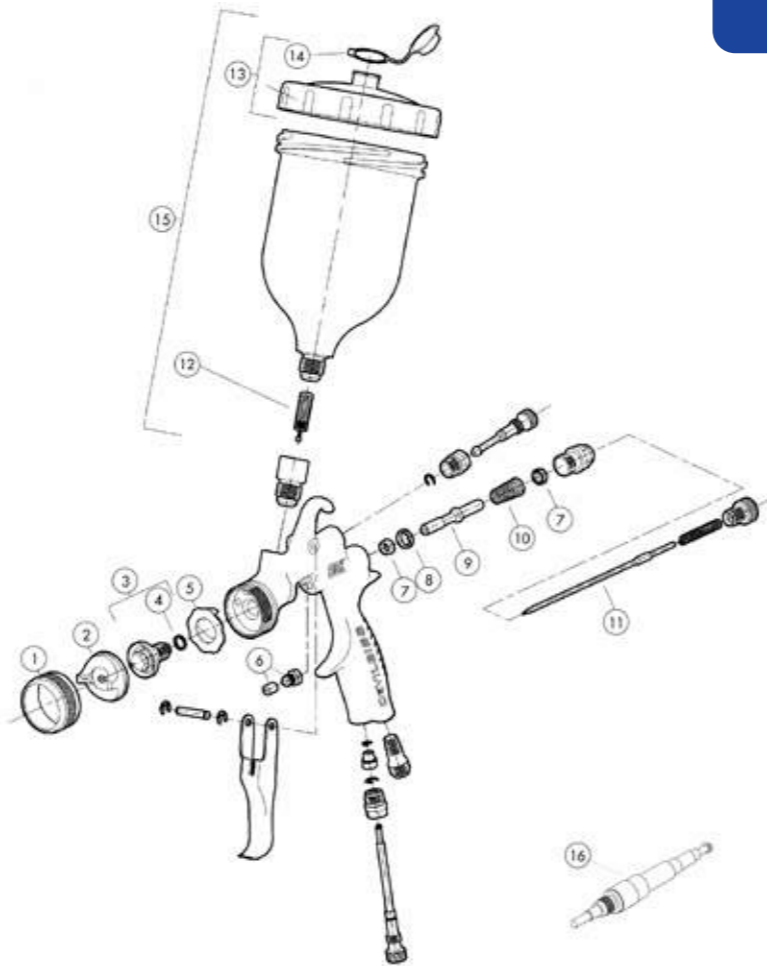

Ref No	Description - Suction Gun	Part No
1	Retaining ring	SGK-23-K
2	Air cap	FLG-1-5-K
3	Fluid tip 1.8mm	SGK-14-18-K
4	Gasket	SGK-43-K10
5	Baffle	*
6	Packing	K-5370
7	U-cup seal	*
8	Air-valve seat	*
9	Air-valve stem	*
10	Air-valve spring	*
11	Fluid needle 1.8mm	SGK-430-18-K
12	Assembly tool	*

- * Seal, baffle and gasket replacement kit, items 4, 5, 6, 7, 8, 9, 10, and 16 905337
- Baffle replacement kit, items 4 and 5 905335

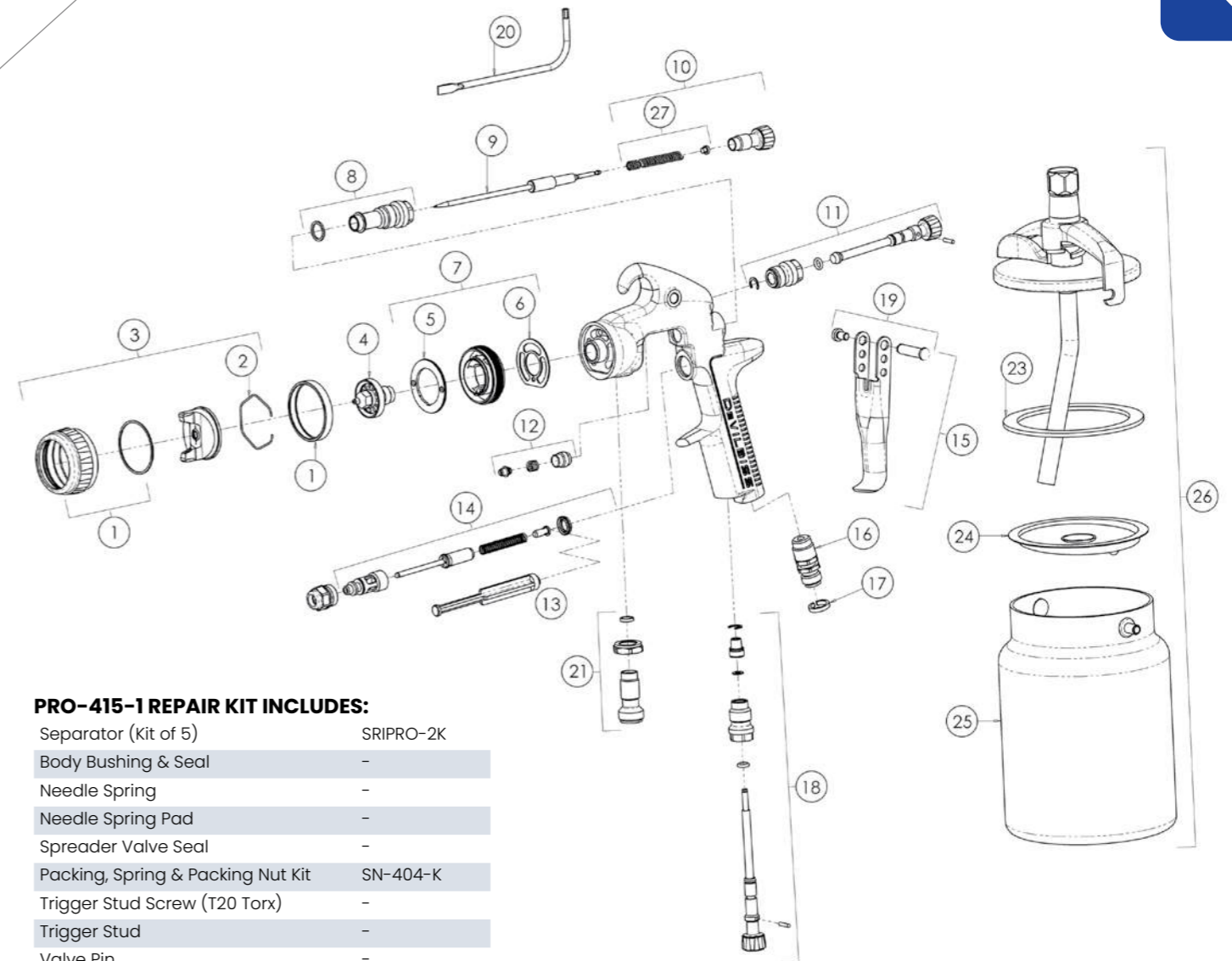
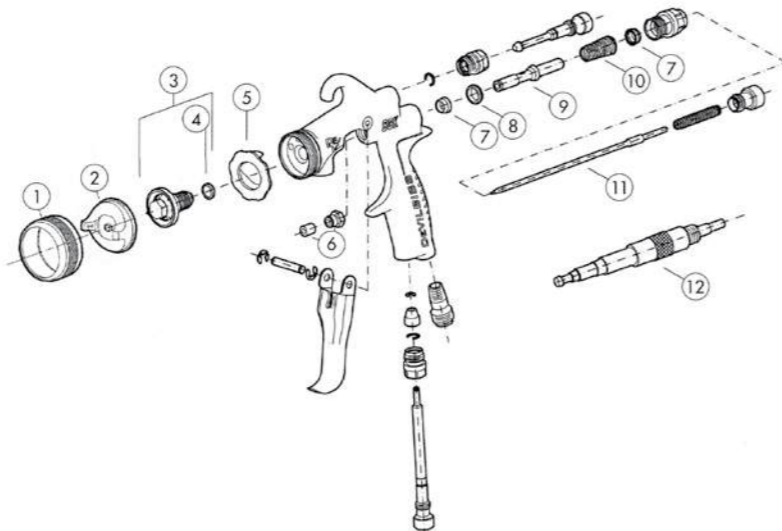

PRO-415-1 REPAIR KIT INCLUDES:

Separator (Kit of 5)	SRIPRO-2K
Body Bushing & Seal	-
Needle Spring	-
Needle Spring Pad	-
Spreader Valve Seal	-
Packing, Spring & Packing Nut Kit	SN-404-K
Trigger Stud Screw (T20 Torx)	-
Trigger Stud	-
Valve Pin	-

Ref No	Description	Part No
1	Air Cap Retaining Clip	905208
2	Air Cap Retaining Clip	905208
3	Aircap & Ring	-
4	Fluid Tip	-
5	Baffle Plate	905297
6	Spray Head Seal (kit of 2)	905287
7	Spray Head & Seal Kit	905303
8	Body Bushing & Seal	905300
9	Fluid Needle	-
10	Fluid Adjusting Knob, Spring & Pad Kit	905285
11	Spreader Valve Assembly	905278
12	Packing, Spring & Packing Nut Kit	905294
13	Air Valve Seal	905290
14	Air Valve Assembly	905293

15	Trigger, Stud & Screw Kit	905288
16	Air Inlet	905305
17	Colour ID Ring Kit (4 Colours)	905289
18	Airflow Valve	905276
19	Stud and Screw kit	905295
20	Torx Key	905307
21	Fluid Inlet Connector Kit	PRO-12-K
22	Cup Lid Assembly	905357
23	Lid Gaskets - kit of 3	905354
24	Drip Free Diaphragms - Kit of 5	905355
25	Cup Only	905358
26	Complete Cup Assembly	905353
27	Needle spring and pad kit	905291

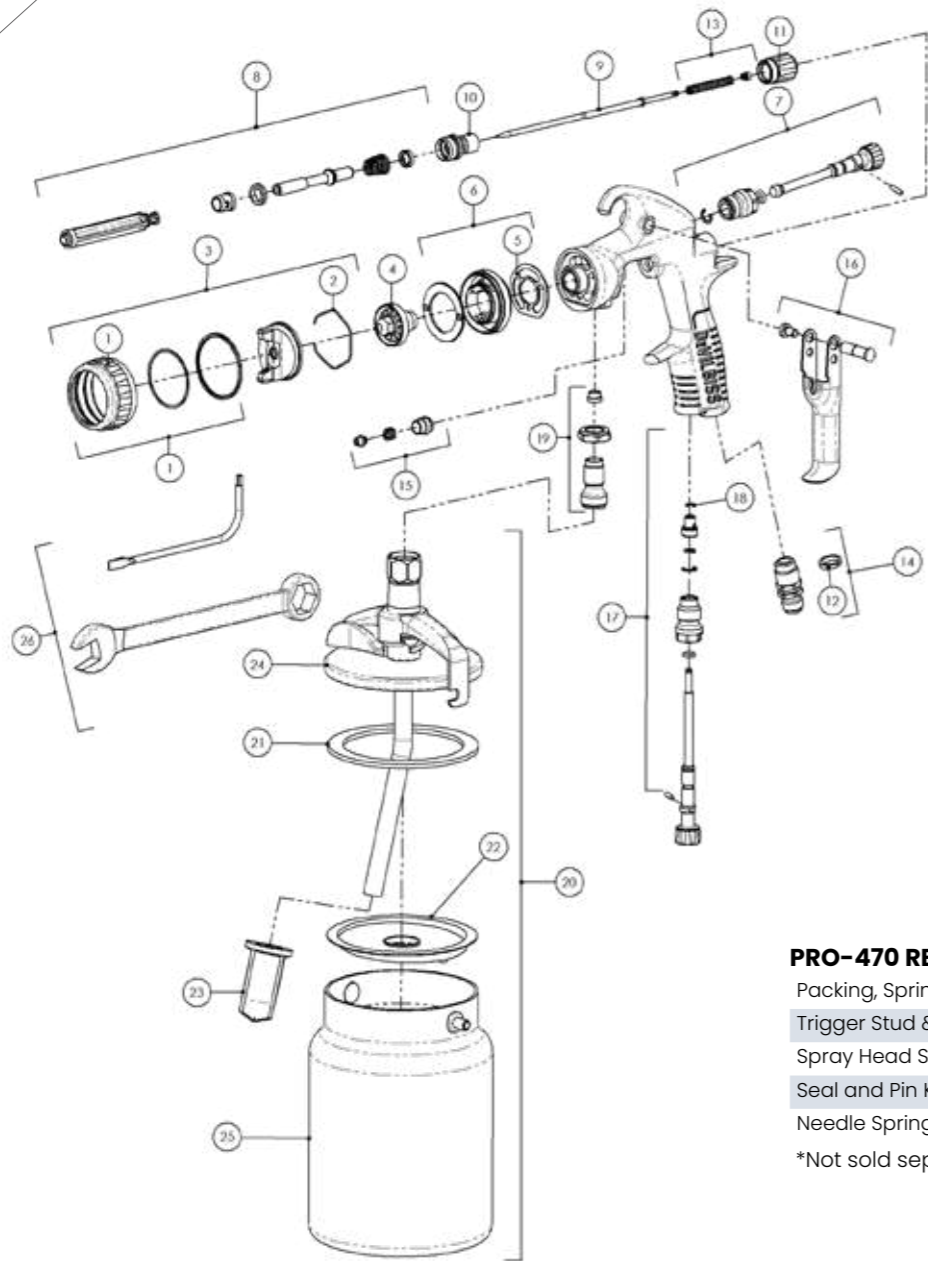

PRO-470 REPAIR KIT INCLUDES:

Packing, Spring & Packing Nut	SN-404
Trigger Stud & Screw*	
Spray Head Seal	SN-18-1
Seal and Pin Kit	GTI-428-K5
Needle Spring	PRO-472

*Not sold separately

Ref No	Description	Part No
1	Air Cap Retaining Clip	905208
2	Air Cap Retaining Clip	905208
3	High Efficiency Aircap & Ring	-
4	Fluid Tip Kit	-
5	Spray Head Seal	905287
6	Spray Head Kit	905303
7	Spreader Valve Assembly	905278
8	Air Valve Kit	905282
9	Fluid Needle	-
10	Housing	905301
11	Fluid Adjusting Knob	905302
12	Colour ID Ring Kit (4 Colours)	905289
13	Needle spring kit	905283
14	Air Inlet Kit	905305

15	Packing, spring and packing nut kit	905294
16	Trigger, stud & Screw Kit	905306
17	Airflow valve	905276
18	Circlip - kit of 5	905200
19	Fluid inlet kit	905201

SUCTION CUP MODELS ONLY

Ref No	Description	Part No
20	Suction cup kit	905353
21	Cup lid gasket - kit of 3	905354
22	Drip check Diaphragm (kit of 5)	905355
23	Filter - kit of 10	905356
24	Lid assembly	905357
25	Cup	905358

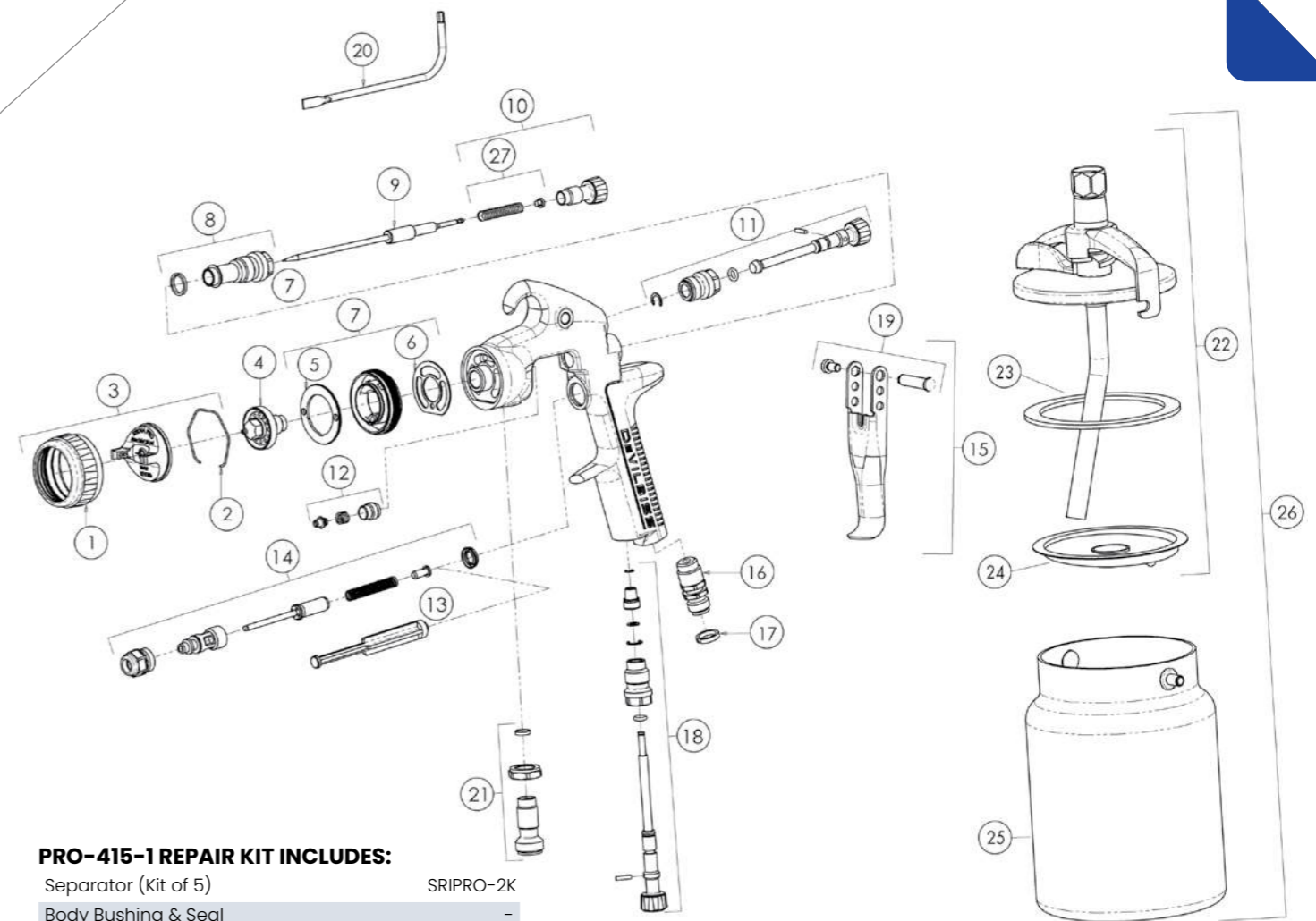

PRO-415-1 REPAIR KIT INCLUDES:

Separator (Kit of 5)	SRIPRO-2K
Body Bushing & Seal	-
Needle Spring	-
Needle Spring Pad	-
Spreader Valve Seal	-
Packing, Spring & Packing Nut Kit	SN-404-K
Trigger Stud Screw (T20 Torx)	-
Trigger Stud	-
Valve Pin	-

Ref No	Description	Part No
1	Air Cap Retaining Clip	PRO-405-K
2	Air Cap Retaining Clip	905208
3	Aircap & Ring	-
4	Fluid Tip	-
5	Baffle Plate	905297
6	Spray Head Seal (kit of 2)	905287
7	Spray Head & Seal Kit	905286
8	Body Bushing & Seal	905300
9	Fluid Needle	-
10	Fluid Adjusting Knob, Spring & Pad Kit	PRO-3-K
11	Spreader Valve Assembly	PRO-404-K
12	Packing, Spring & Packing Nut Kit	905294
13	Air Valve Seal	905290
14	Air Valve Assembly	905293

15	Trigger, Stud & Screw Kit	905288
16	Air Inlet	905292
17	Colour ID Ring Kit (4 Colours)	905289
18	Airflow Valve	PRO-411-K
19	Stud and Screw kit	905295
20	Torx Key	905307
21	Fluid Inlet Connector Kit	PRO-12-K
22	Cup Lid Assembly	905357
23	Lid Gaskets - kit of 3	905354
24	Drip Free Diaphragms - Kit of 5	905355
25	Cup Only	905358
26	Complete Cup Assembly	905353
27	Needle spring and pad kit	905291

PRO-450-**-** Air cap, fluid tip and needle kit (Part 8, 2 & 4)

Kit Part No.	Air Cap	Fluid Tip
PRO-450-	HI	12
	T1	13
	T2	14

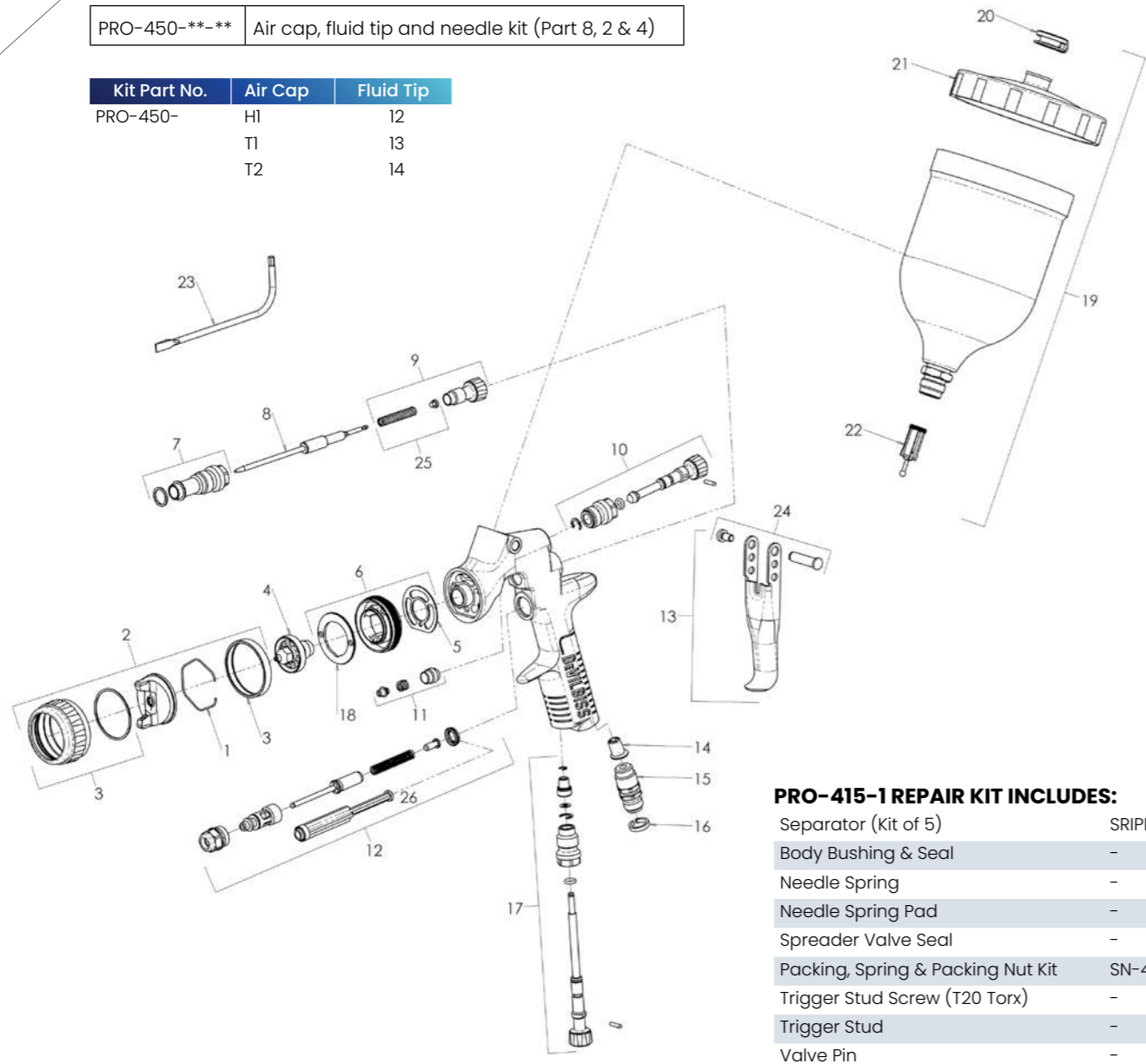

PRO-415-1 REPAIR KIT INCLUDES:

Separator (Kit of 5)	SRIPRO-2K
Body Bushing & Seal	-
Needle Spring	-
Needle Spring Pad	-
Spreader Valve Seal	-
Packing, Spring & Packing Nut Kit	SN-404-K
Trigger Stud Screw (T20 Torx)	-
Trigger Stud	-
Valve Pin	-

Ref No	Description	Part No
1	Air Cap Retaining Clip	JGA-156-K5
2	T1 Trans-tech [®] Aircap & Ring	PRO-100-T1-K
	T2 Trans-tech [®] Aircap & Ring	PRO-100-T2-K
	HI HVLP Aircap & Ring	PRO-100-HI-K
3	Air Cap Retaining Ring & Seals	PRO-405-K
4	Fluid Tip - 12, 13, 14	PRO-200-**-K
5	Spray Head Seal (kit of 2)	SN-18-1-K2
6	Spray Head & Seal Kit	SN-17-1-K
7	Body Bushing & Seal	SN-6-K
8	Fluid Needle	PRO-300-K
9	Fluid Adjusting Knob, Spring & Pad Kit	PRO-3-K
10	Spreader Valve Assembly	PRO-402-K
11	Packing, Spring & Packing Nut Kit	SN-404-K
12	Air Valve Replacement Kit	SN-402-K

13	Trigger, Stud & Screw Kit	SN-21-K
14	Insert - Pack of 5 (with DGI Pod Only)	SN-57-K5
15	Air Inlet	SN-40-K
16	Colour ID Ring Kit (4 Colours)	SN-26-K4
17	Airflow Valve	PRO-411-K
18	Baffle plate	SN-41-K
19	Gravity Cup Kit	GFC-501
20	Drip Check Lid (kit of 5)	GFC-2-K5
21	Gravity Cup Lid	GFC-402
22	Filter	KGP-5-K5
23	Torx Key	SPN-8-K2
24	Trigger Stud & Torx Screw (kit of 5)	SN-405-K5
25	Needle spring and pad kit	SN-4-K3
26	Air valve seal & service tool	SN-34-K5

PRIPRO-450-**-** Air cap, fluid tip and needle kit (Part 8, 2 & 4)

Kit Part No.	Air Cap	Fluid Tip
PRIPRO-450-	PI	14
		16
		18
		20
		25

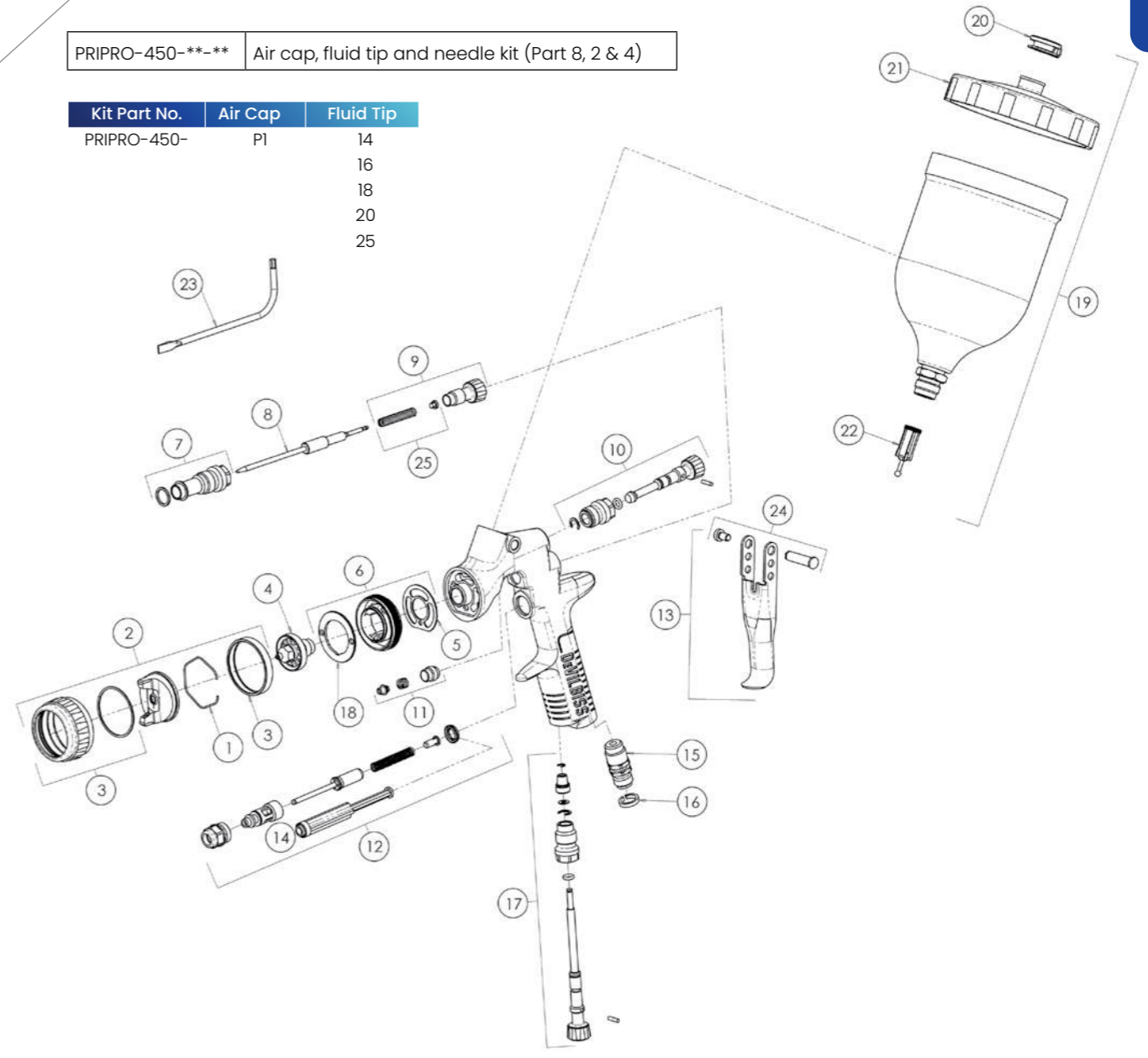

Ref No	Description	Part No
1	Air Cap Retaining Clip	JGA-156-K5
2	Trans-tech [®] Aircap	PRIPRO-100-PI-K
3	Air Cap Retaining Ring & Seals	PRO-405-K
4	Fluid Tip - 14, 16, 18, 20, 25	PRIPRO-210-**-K
5	Spray Head Seal (kit of 2)	SN-18-1-K2
6	Spray Head & Seal Kit	SN-17-1-K
7	Body Bushing & Seal	SN-6-K
8	Fluid Needle	PRIPRO-310-K
9	Fluid Adjusting Knob, Spring & Pad Kit	PRO-3-K
10	Spreader Valve Assembly	PRO-402-K
11	Packing, Spring & Packing Nut Kit	SN-404-K
12	Air Valve Replacement Kit	SN-402-K
13	Trigger, Stud & Screw Kit	SN-21-K

14	Air valve seal & service tool	SN-34-K5
15	Air Inlet	SN-40-K
16	Colour ID Ring Kit (4 Colours)	SN-26-K4
17	Airflow Valve	PRO-411-K
18	Baffle plate	SN-41-K
19	Gravity Cup Kit	GFC-501
20	Drip Check Lid (kit of 5)	GFC-2-K5
21	Gravity Cup Lid	GFC-402
22	Filter	KGP-5-K5
23	Torx Key	SPN-8-K2
24	Trigger Stud & Torx Screw (kit of 5)	SN-405-K5
25	Needle spring and pad kit	SN-4-K3

SRIPRO-450-**-** Air cap, fluid tip and needle kit (Part 1, 2 & 4)

Kit Part No.	Air Cap	Fluid Tip
SRIPROL-450-	TSI	08
	HSI	10
		12

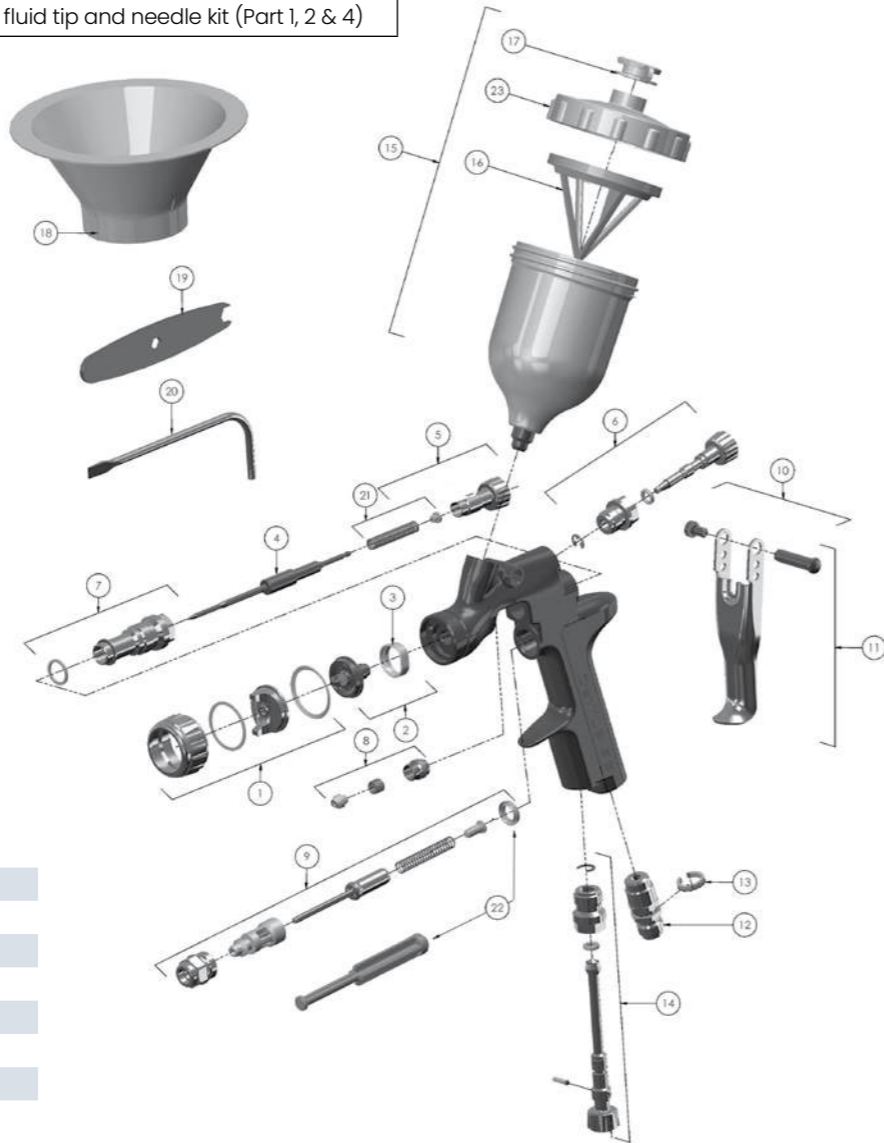

PRO-415-1 REPAIR KIT INCLUDES:

Seal & Pin Kit (5 Pack)	GTI-428 K5
Fluid Needle Spring (Sub Assy)	SN-409
Needle Packing	SN-404
Body Bushing Gasket	SN-8
Trigger Stud	SN-13
Sprayhead Gasket	SN-18-1
Screw	SN-22
Separator	SRIPRO-2

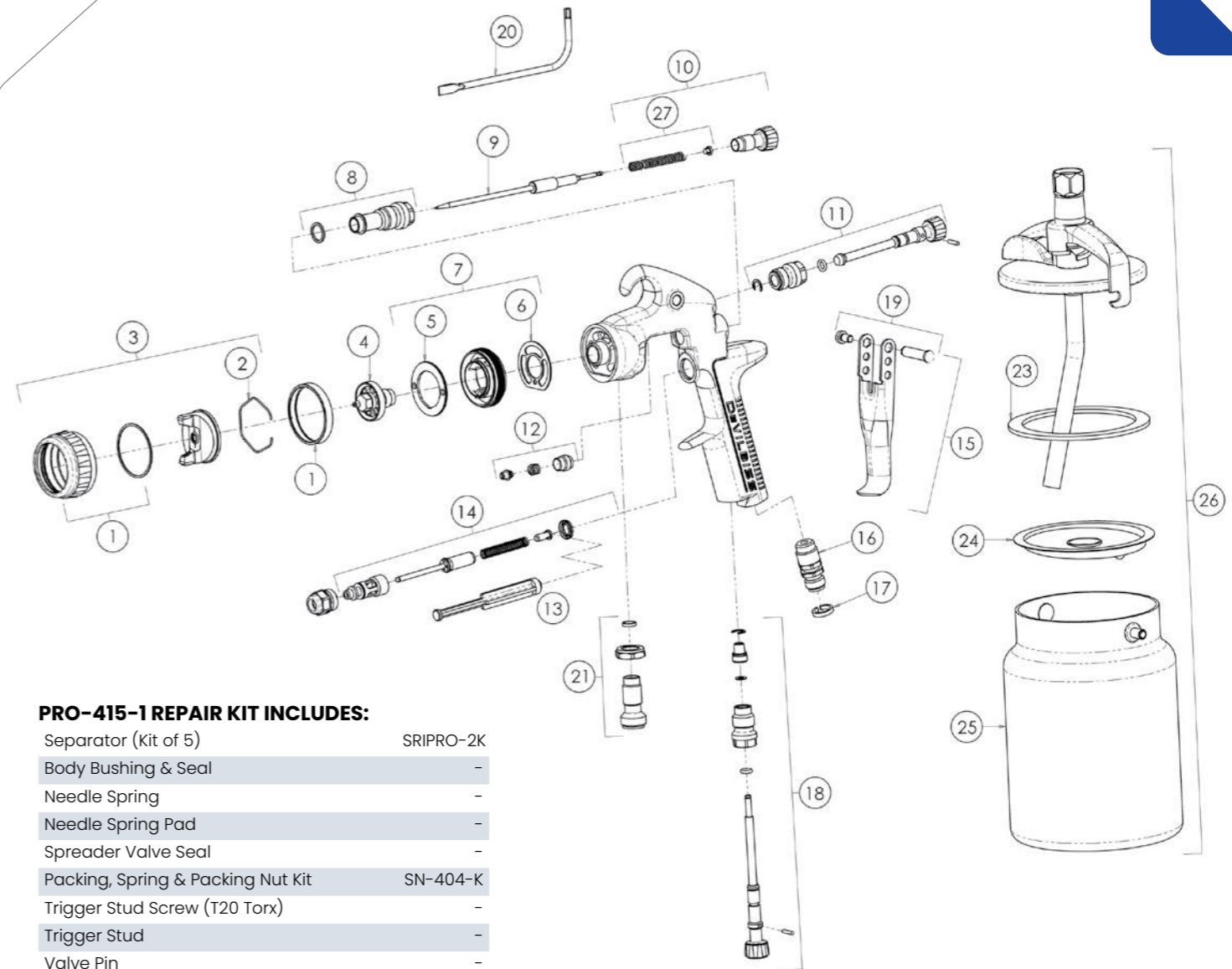

PRO-415-1 REPAIR KIT INCLUDES:

Separator (Kit of 5)	SRIPRO-2K
Body Bushing & Seal	-
Needle Spring	-
Needle Spring Pad	-
Spreader Valve Seal	-
Packing, Spring & Packing Nut Kit	SN-404-K
Trigger Stud Screw (T20 Torx)	-
Trigger Stud	-
Valve Pin	-

Ref No	Description	Part No
1	HVLP Air Cap & Ring	SRIPRO-100-HSI-K
	Trans-Tech Air Cap & Ring	SRIPRO-100-TSI-K
	Round Spray Air Cap & Ring	SRIPRO-100-RSI-K
2	Fluid Tip (** = 08, 10, 12 or 14)	SRIPRO-200-**-K
3	Separator	SRIPRO-2-K5
4	Fluid Needle for No. 08 & No. 10 Fluid Tips	SRIPRO-300-08-10-K
	Fluid Needle for No. 12 & No. 14 Fluid Tips	SRIPRO-300-12-14-K
5	Fluid Adjusting Knob, Spring & Pad Kit	PRO-3-K
6	Spreader Valve Assembly	SRIPRO-401-K
7	Body Bushing & Seal	SN-6-K
8	Packing, Spring & Packing Nut Kit	SN-404-K
9	Air Valve Assembly	SN-402-K

10	Stud and Screw kit	SN-405-K5
11	Trigger, Stud & Screw Kit	SN-42-K
12	Air Inlet	SN-40-K
13	Colour ID Ring Kit (4 Colours)	SN-26-K4
14	Airflow Valve	PRO-404-K
15	Gravity Cup Kit	SRI-510
16	Filter	SRI-42-K3
17	Drip Check Lid (kit of 5)	GFC-2-K5
18	Funnel kit of 12	SRI-51-K12
19	Spanner kit of 2	SRI-50-K2
20	Torx Key	SPN-8-K2
21	Needle spring and pad kit	SN-4-K3
22	Air valve seal & service tool	SN-34-K5
23	Gravity Cup Lid	SRI-414-K2

Ref No	Description	Part No
1	Air Cap Retaining Ring	PRO-405-K
2	Air Cap Retaining Clip	JGA-156-K5
3	Aircap & Ring (HI, TI, T2, T4)	PRO-100-**-K
4	Fluid Tip (16, 18, 20)	PRO-200-**-K
5	Baffle Plate	SN-41-K
6	Spray Head Seal (kit of 2)	SN-18-1-K2
7	Spray Head & Seal Kit	SN-17-1-K
8	Body Bushing & Seal	SN-6-K
9	Fluid Needle	PRO-315-K
10	Fluid Adjusting Knob, Spring & Pad Kit	PRO-3-K
11	Spreader Valve Assembly	PRO-404-K
12	Packing, Spring & Packing Nut Kit	SN-404-K
13	Air Valve Seal	SN-34-K5

14	Air Valve Assembly	SN-402-K
15	Trigger, Stud & Screw Kit	SN-21-K
16	Air Inlet	SN-40-K
17	Colour ID Ring Kit (4 Colours)	SN-26-K4
18	Airflow Valve	PRO-411-K
19	Stud and Screw kit	SN-405-K5
20	Torx Key	SPN-8-K2
21	Fluid Inlet Connector Kit	PRO-12-K
22	Cup Lid Assembly	KR-4001-B
23	Lid Gaskets - kit of 3	KR-11-K3
24	Drip Free Diaphragms - Kit of 5	KR-115-K5
25	Cup Only	KR-466-K
26	Complete Cup Assembly	KR-566-1-B
27	Needle spring and pad kit	SN-4-K3

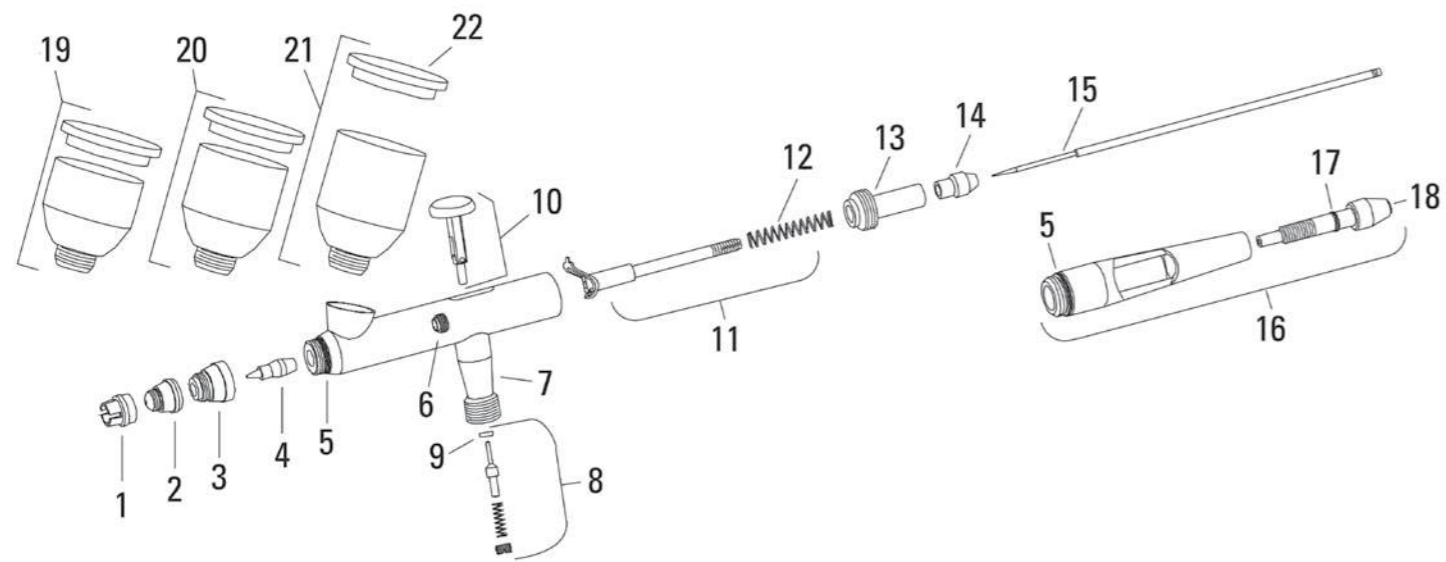

Ref No	Description	Part No
1	Crown cap	DGR-101
2	Air cap (for .35mm Tip)	DGR-103-35
3	Head cap	DGR-104
4	Tip (.35mm)	DGR-105-35
* 5	O-ring (head cap & handle)	-
6	Packing and nut assembly (PTFE)	DGR-106K
7	Air valve casing	DGR-107
8	Air valve kit	DGR-108K
* 9	Air valve washer	-
10	Trigger assembly	DGR-323
11	Needle guide, rocker and spring	DGR-110K
* 12	Needle spring	-
13	Spring guide	DGR-111
14	Needle locknut	DGR-112

15	Needle (for .35mm tip)	DGR-113-35
16	Cutaway handle w/pre-set	DGR-114
* 17	O-ring (pre-set needle knob)	-
18	Pre-set needle knob	DGR-116
19	1/4 oz. (7 cc) cup and lid	DGR-117
20	1/3 oz. (9 cc) cup and lid (standard)	DGR-118
21	1/2 oz. (14 cc) cup and lid	DGR-119
22	Cup lid	DGR-120

REPAIR KIT

DAGR repair kit - includes item numbers 5, 9, 12 & 17
DGR-121K

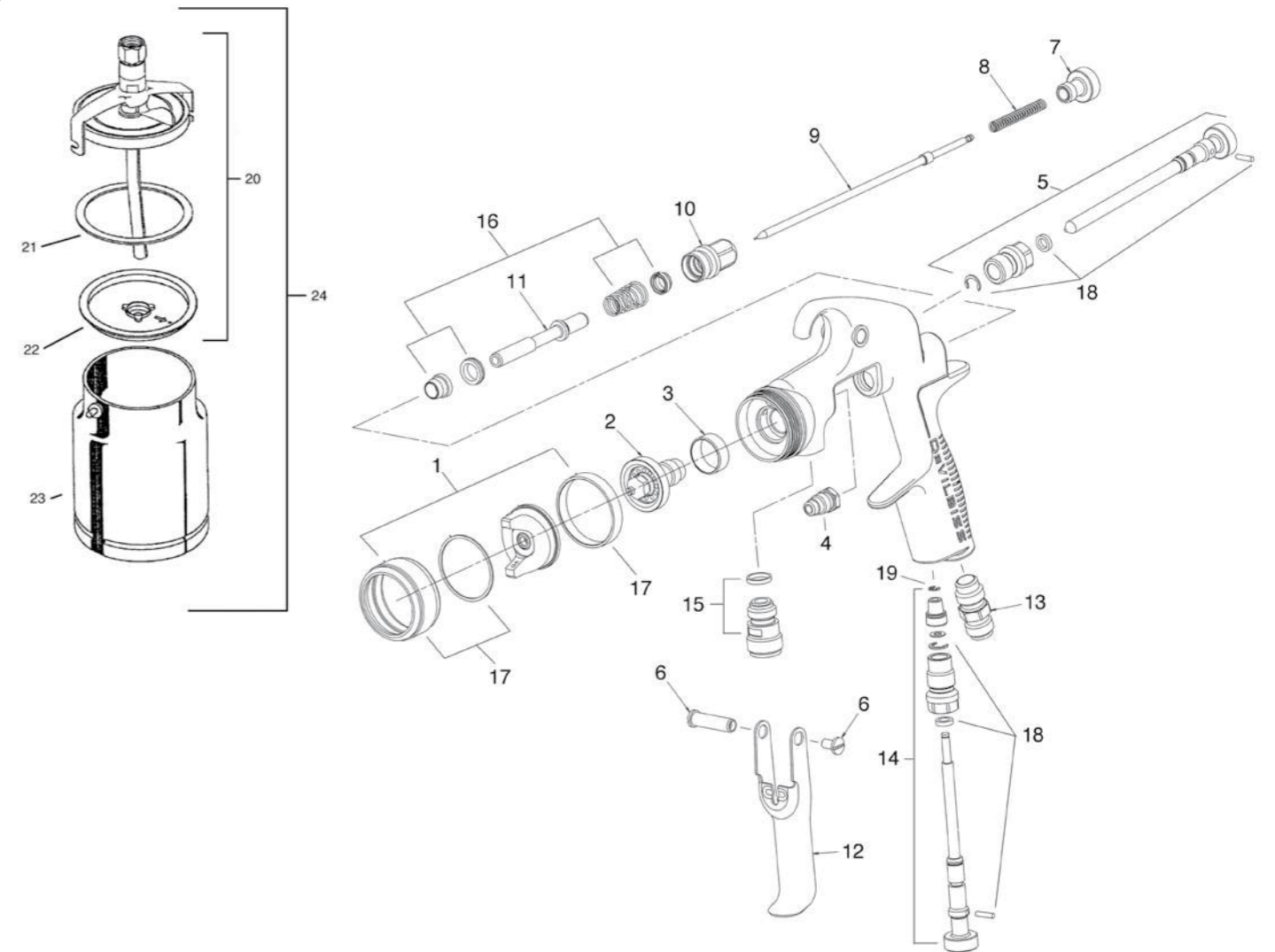

Ref No	Description	Part No
1	Air Cap Retaining Ring	SP-100-510-K
2	Tip (** = 1.0, 1.4, 1.6, 1.8, 2.0, 2.2mm)	SP-200S-**-K
3	Separator	SP-623-K5
4	Packing	GTI-445-K2
5	Spreader Valve	SP-401-K
6	Stud and Screw	GTI-408-K5
7	Needle Adjusting Screw	SP-614-K
8	Spring	SP-622-K5
9	Needle (** = 1.0, 1.4, 1.6, 1.8, 2.0, 2.2mm)	SP-300S-**-K
10	Airvalve housing + seal	SP-612-K
11	Spindle	-
12	Trigger	SP-617-CR-K

13	Connector	SP-611-K
14	Airflow Valve	SP-402-K
15	Fluid Inlet Connector and seal	SP-610-K
16	Air Valve Service Kit	SPK-101-K
17	Retaining Ring and Seals	SPK-102-K
18	Spreader/ Cheater Service Kit	GTI-428-K5
19	Circlip	25746-007-K5
20	Cup Lid Assembly	KR-4001-B
21	Lid Gasket - Kit of 3	KR-11-K3
22	Drip Free Diaphragm - Kit of 5	KR-115-K5
23	Cup	KR-466-K
24	Complete Cup	KR-566-1-B

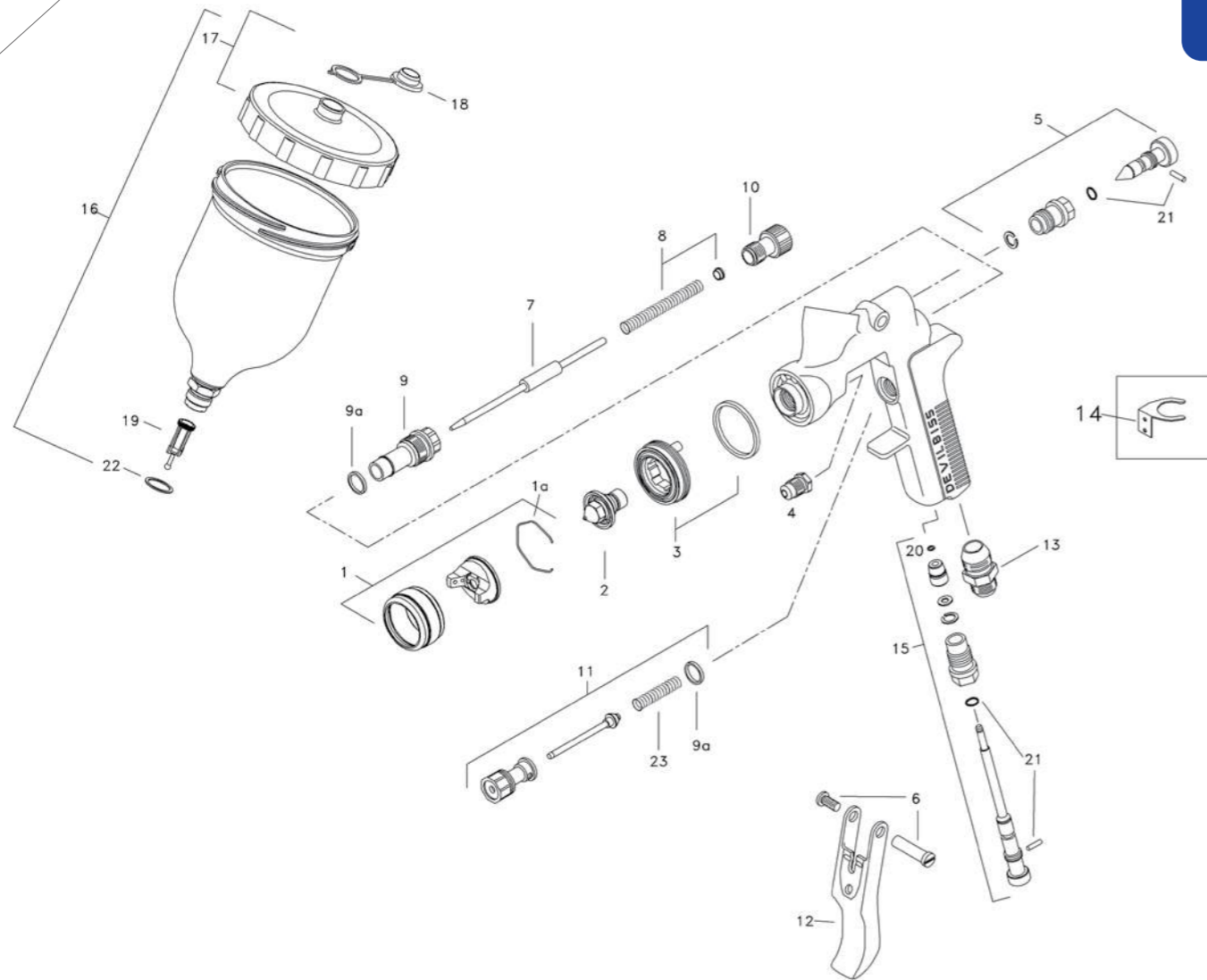

Ref No	Description	Part No
1	GTi-W Air Cap / Retaining ring	GTI-407-115
	GTi-G Air Cap / Retaining ring	GTI-407-110
	PRI Air Cap / Retaining ring	PRI-407-310
1a	Spring Clip	JGA-156-K5
2	GTi-W Tip (1.3, 1.4 & 1.5mm)	GTI-213-**-K
	GTi-G Tip (1.2, 1.3, 1.4 & 1.5mm)	GTI-213-**-K
	PRI Tip (1.6, 1.8, 2.0, 2.2 & 2.5mm)	PRI-2-**-K
3	Baffle & Seal	GTI-425-K
	Baffle Seal - Kit of 5	GTI-33-K5
4	Packing	GTI-445-K2
5	Spreader Valve	GTI-404-K
6	Stud and Screw	GTI-408-K5
7	GTi Needle	GTI-413-K
	PRI Needle	PRI-3-K
8	Spring and Pad	GTI-409-K5
9	Bushing	GTI-402-K
9a	Seal kit of 5	JGS-72-K5

10	Needle Adjusting Screw	GTI-414-K
11	Valve Assembly	JGK-449-K
12	Trigger	GTI-108
13	Connector	JGA-158
14	Gun Hook	GFG-6
15	Airflow Valve	GTI-415-K
16	1/2 Ltr Gravity Cup Kit	GFC-501
17	Cup Lid	GFC-402
18	Drip Check Lid kit of 5	GFC-2-K5
19	Filter	KGP-5-K5
20	Circlip	25746-007-K5
21	Seal & Pin Kit (+SST8434-K5)	GTI-428-K5
22	Washer	GFC-17-K5
23	Spring	JGV-262-K5
	Service Kit for GTI gravity and suction - 12, 13, 14, 15, 16, 18, 20, 22 tip	GTI-416-**-
	Service Kit for PRI - 16, 18, 20, 22, 25 tip	PRI-416-**-

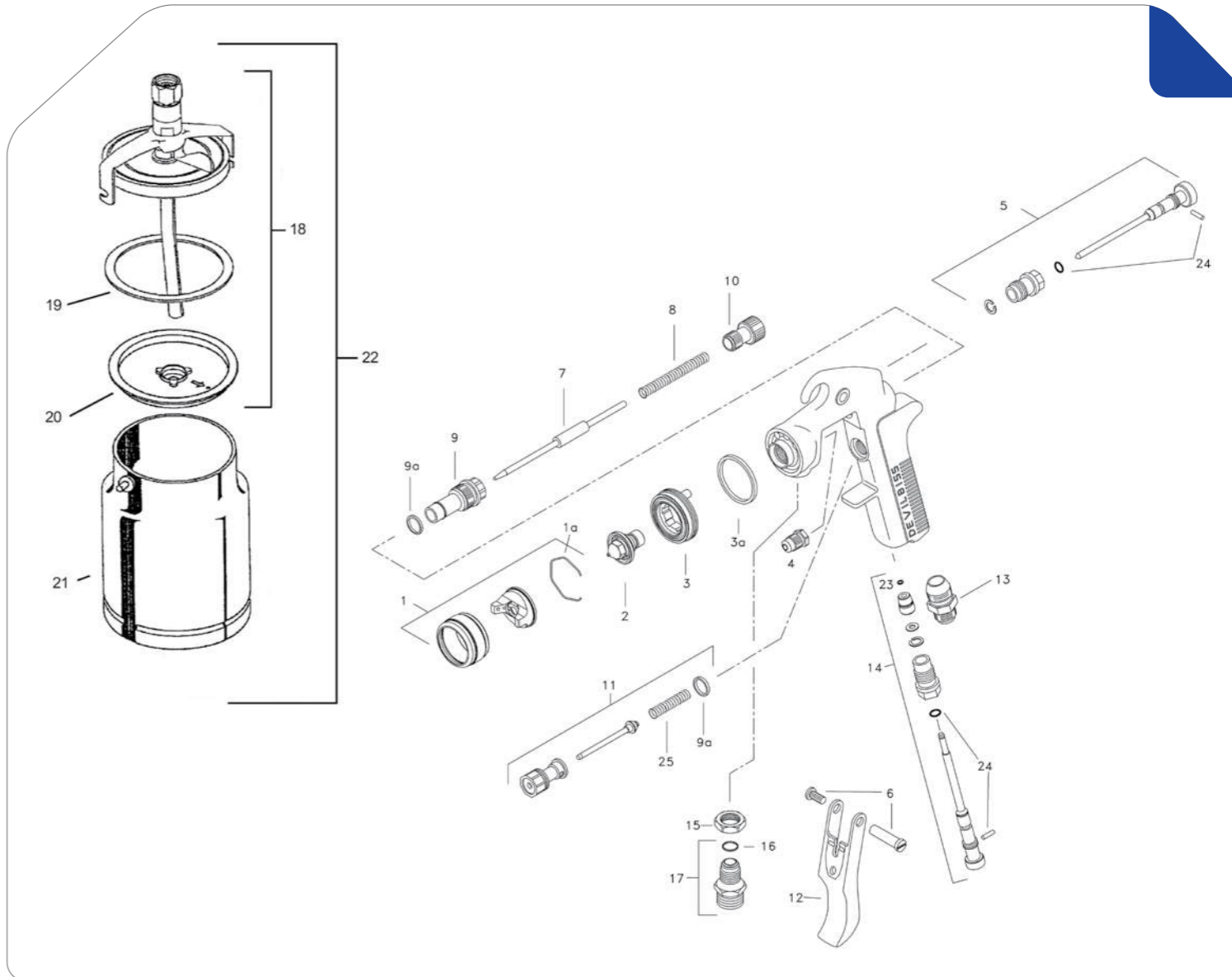

Ref No	Description	Part No
1	GTI-P air cap/retaining ring	GTI-407-123
	GTI-S air cap/retaining ring	GTI-407-110
1a	Spring Clip	JGA-156-K5
2	GTI-P Tip	GTI-213-**-K
	GTI-S Tip	GTI-214-**-K
3	Baffle & Seal	GTI-425-K
	Baffle seal-Kit of 5	GTI-33-K5
4	Packing	GTI-445-K2
5	Spreader Valve	GTI-405-K
6	Stud and Screw	GTI-408-K5
7	GTI-P needle	GTI-449-**-K
	GTI-S needle (for GTI-214 Tip)	GTI-420-K
8	Spring and Pad	GTI-409-K5
9	Bushing	GTI-402-K
9a	Seal kit of 5	JGS-72-K5
10	Needle Adjusting Screw	GTI-414-K

11	Valve Assembly	JGK-449-K
12	Trigger	GTI-108
13	Connector	JGA-158
14	Airflow Valve	GTI-415-K
15	Lock Nut	JGA-51-K5
16	Seal	23165-001
17	Fluid Inlet Connector and seal	JGA-159-K
18	Cup lid assembly	KR-4001-B
19	Lid Gasket - kit of 3	KR-11-K3
20	Drip free diaphragm - kit of 5	KR-115-K5
21	Cup	KR-466-K
22	Complete cup	KR-566-1-B
23	Circlip	25746-007-K5
24	Seal & Pin Kit	GTI-428-K5
25	Spring	JGV-262-K5

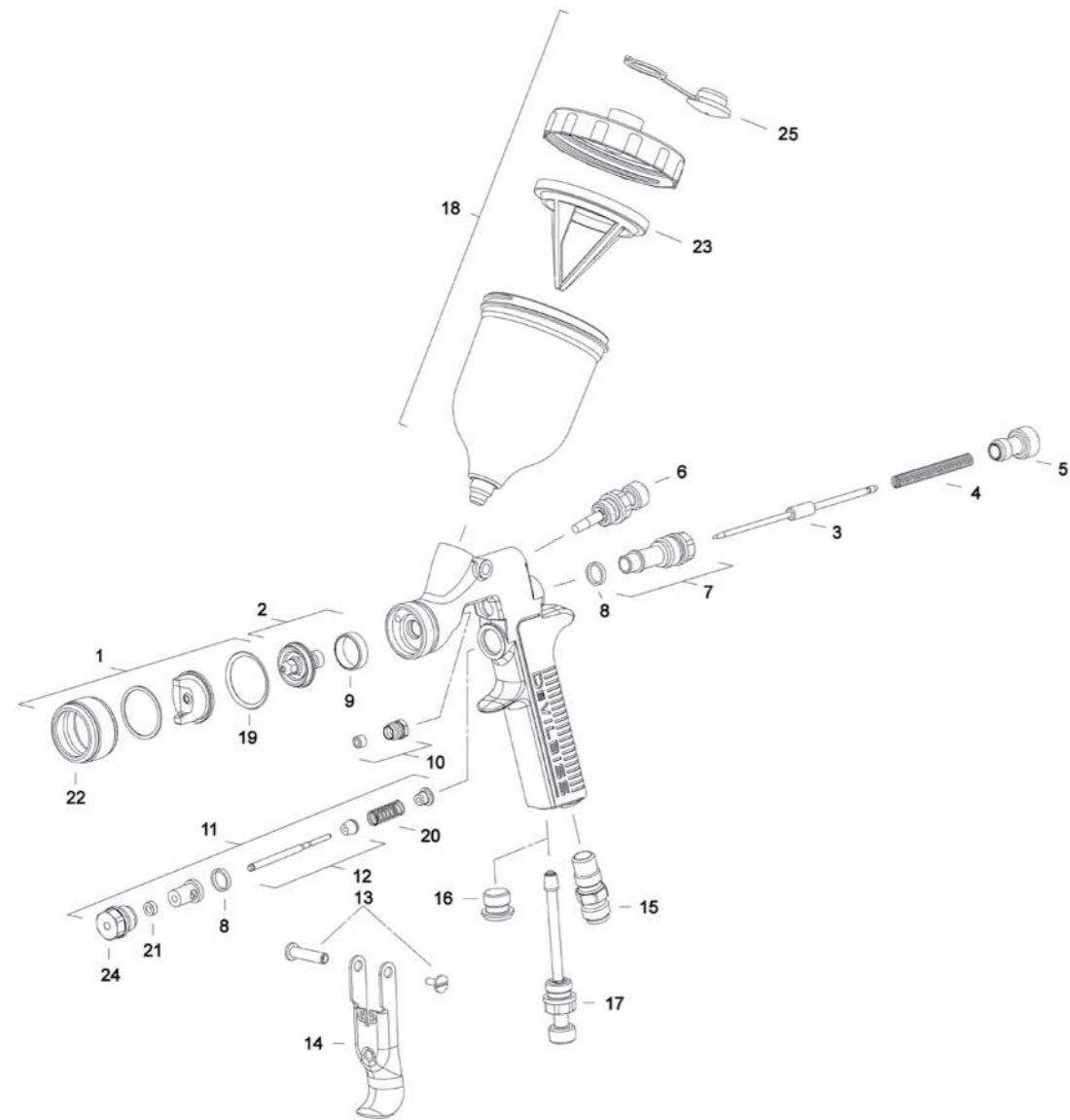

Ref No	Description	Part No
1	Air Cap/Retaining ring Trans-Tech	SRI-407-210
		SRI-407-200
1 (SRIW)	Air Cap/Retaining ring HVLP	SRI-407-215
2	Tip 0.7 mm & seal	SRI-2-07-K
	Tip 0.8 mm & seal	SRI-2-08-K
	Tip 1.0 mm & seal	SRI-2-10-K
	Tip 1.2 mm & seal	SRI-2-12-K
3	Needle for 1.0 and 1.2 mm Tip	SRI-3-K
	Needle for 0.7 and 0.8 mm Tip	SRI-37-K
4	Needle Spring	SRI-18-K2
5	Needle Adjusting Knob	SRI-19-K2
6 (SRI)	Spreader Valve	SRI-401-K
6 (SRIW)	Spreader Valve	SRI-415-K
7	Body Bushing and Seal Kit	SRI-17-K
8	Seal	SRI-16-K5
9	Separator	SRI-6-K5
10	Needle Packing Kit of 3	SRI-411-K3

11	Air Valve Assembly	SRI-404-K
12	Air Valve Stem Assembly	-
13	Trigger Stud and Screw Kit	SRI-412-K
14	Trigger	SRI-9-K
15 (SRI)	Air Inlet Adaptor	SRI-20-K
15 (SRIW)	Air Inlet Adaptor	SRI-40-K
16	Blanking Plug (to replace airflow valve)	SRI-21
17	Airflow Valve	SRI-402-K
18	Cup	SRI-510
19	Aircap Seal	SRI-35-K5
20	Airvalve Spring	SRI-23-K2
21	Airvalve Seal	-
22	Retaining Ring	-
23	Filter	SRI-42-K3
24	Airvalve Body	-
25	Drip Check Lid Kit of 5	GFC-2-K5
	Service Kit for SRI/SRIW	SRI-416

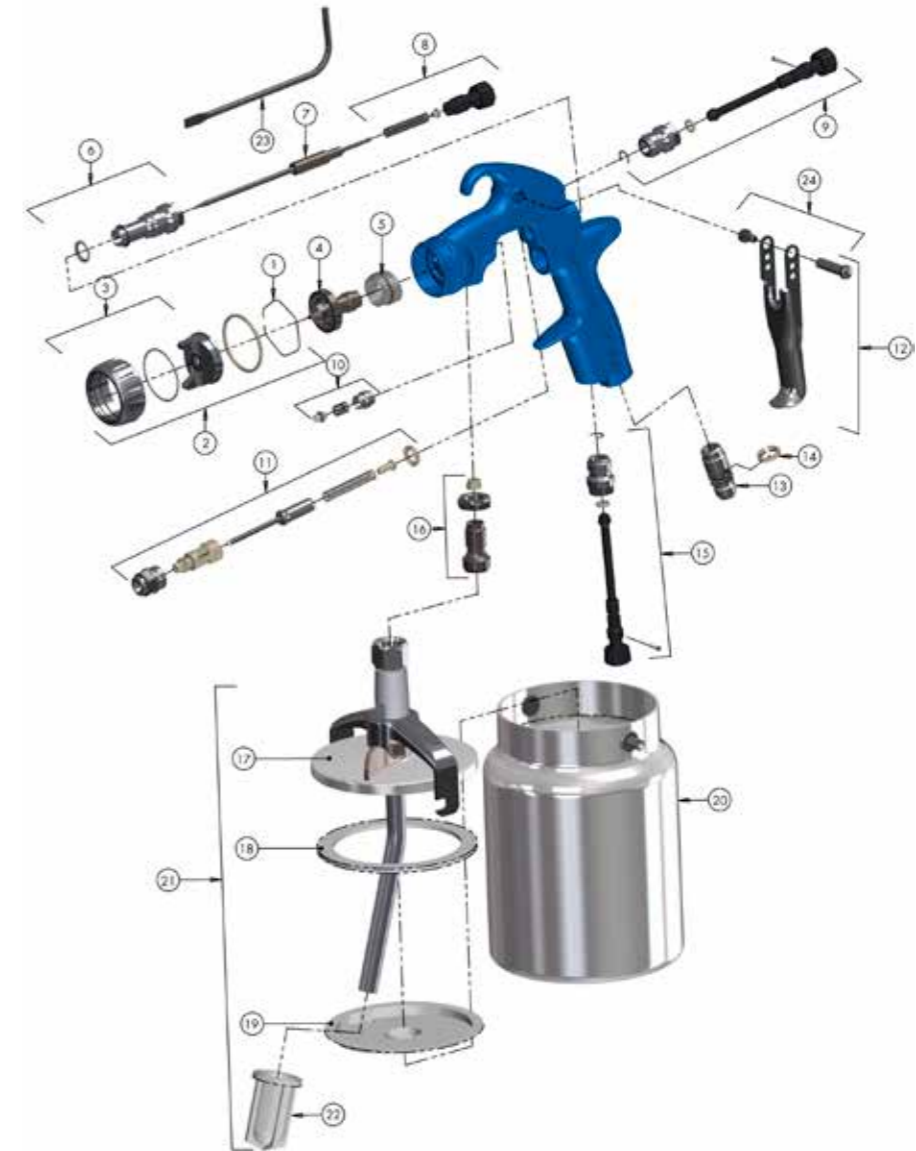

Ref No	Description	Part No
1	Air Cap Retaining Clip	JGA-156-K5
2	Suction Feed Trans-tech* Aircap	VRIPRO-100-TVI-K
	Pressure Feed Trans-tech* Aircap	VRIPRO-100-TV2-K
3	Air Cap Retaining Ring & Seals	ADV-403-K
4	Fluid Tip - 0.85,14, 16, 18	SP-200S-**-K
5	Separator	SP-626-K5
6	Body Bushing & Seal	SN-6-K
7	Fluid Needle - 0.85, 1.4, 1.6, 1.8 mm	ADV-310-**-K
8	Fluid Adjusting Knob, Spring & Pad Kit	ADV-6-K
9	Spreader Valve Assembly	ADV-401-K
10	Packing, Spring & Packing Nut Kit	SN-404-K
11	Air Valve Replacement Kit	SN-402-K
12	Trigger, Stud & Screw Kit	SN-63-K
13	Air Inlet	SN-9-K
14	Colour ID Ring Kit (4 Colours)	SN-26-K4

15	Airflow Valve	ADV-401-K
16	Fluid Inlet Connector and seal	ADV-7-K
17	Cup lid assembly	KR-4001-B
18	Lid Gasket - kit of 3	KR-11-K3
19	Drip free diaphragm - kit of 5	KR-115-K5
20	Cup	KR-466-K
21	Complete cup	KR-566-1-B
22	Filter	KR-484-K10
23	Torx Key	SPN-8-K2
24	Trigger Stud & Torx Screw (kit of 5)	SN-405-K5

SERVICE PARTS

Spray Gun repair kit	PRO-415-1
Seal and Pin Kit, kit of 5	GTI-428-K5

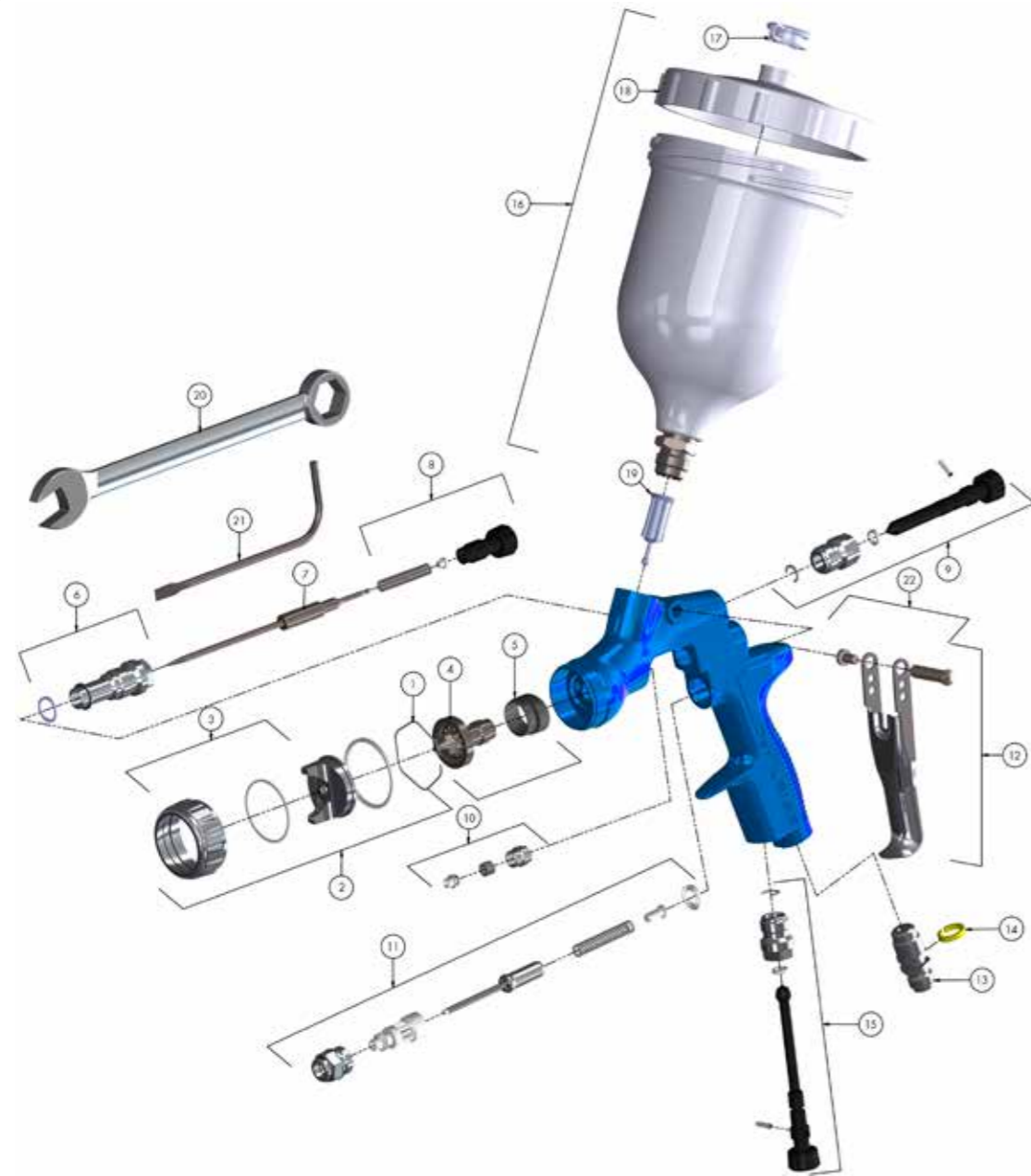

Ref No	Description	Part No
1	Air Cap Retaining Ring	JGA-156-K5
2	Gravity Feed Trans-tech [®] Air Cap	VRIPRO-100-TVI-K
3	Air Cap Retaining Ring & Seals	ADV-403-K
4	Fluid Tip 12 or 13	SP-200S-XX-K
5	Separator	SP-626-K5
6	Body Bushing & Seal	SN-6-K
7	Fluid Needle 12 or 13	ADV-310-**-K
8	Fluid Adjusting Knob, Spring & Pad Kit	ADV-6-K
9	Spreader Valve Assembly	ADV-402-K
10	Packing, Spring & Packing Nut Kit	SN-404-K
11	Air Valve Replacement Kit	SN-402-K
12	Trigger, Stud & Screw Kit	SN-63-K
13	Air Inlet	SN-9-K

14	Colour ID Ring Kit (4 Colours)	SN-26-K4
15	Airflow Valve	ADV-401-K
16	Gravity Cup Kit	GFC-501
17	Drip Check Lid (kit of 5)	GFC-2-K5
18	Gravity Cup Lid	GFC-402
19	Filter	KGP-5-K5
20	Spanner, Torx, Brush & ID Rings	SN-406
21	Torx Key	SPN-8-K2
22	Trigger Stud & Torx Screw (kit of 5)	SN-405-K5

SERVICE PARTS

	Spray Gun repair kit	PRO-415-1
	Seal and Pin Kit, kit of 5	GTI-428-K5

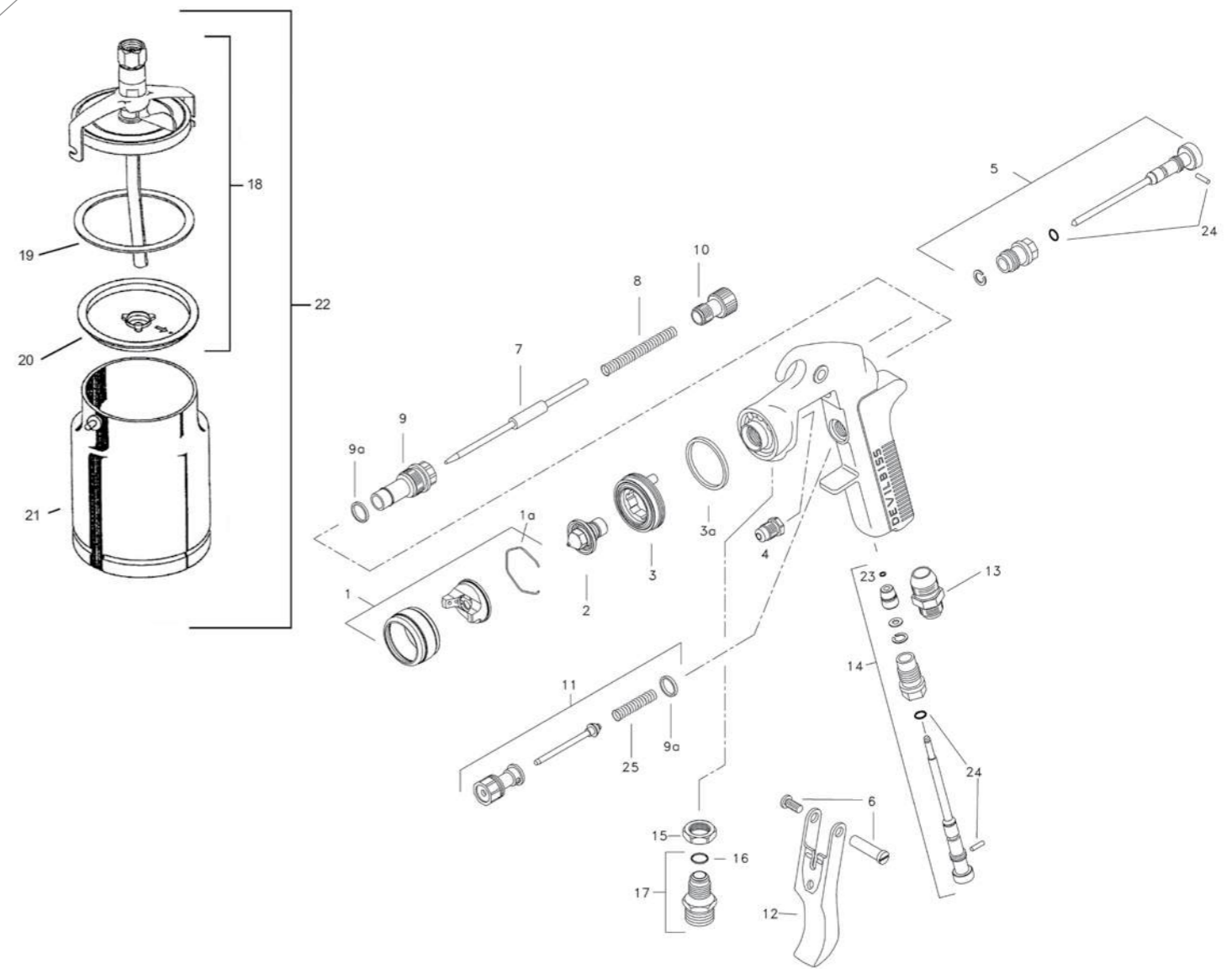

Ref No	Description	Part No
1	Air Cap/Retaining ring (* = 186+ or 30+)	AV-4239-***
1a	Spring Clip - Kit of 5	JGA-156-K5
2	Tip (* = EX-1.8mm, FF-1.4mm, FW-1.6mm)	AV-645-*
3	Baffle & Seal	JGD-402-K
3a	Baffle seal - Kit of 5	GTI-33-K5
4	Packing	GTI-445-K2
5	Spreader Valve	GTI-405-K
6	Stud and Screw	GTI-408-K5
7	Needle (* = DEX, FF or FW)	JGA-421-**-K
8	Spring - Kit of 5	GTI-409-K5
9	Bushing	JGA-17
9a	Seal - Kit of 5	JGS-72-K5
10	Needle Adjusting Screw	GTI-414-K
11	Valve Assembly	JGK-449-K

12	Trigger	GTI-108
13	Connector	JGA-158
14	Airflow Valve	GTI-415-K
15	Lock Nut - Kit of 5	JGA-51-K5
16	Seal	23165-001
17	Fluid Inlet Connector and seal	JGA-159-K
18	Cup lid assembly	KR-4001-B
19	Lid Gasket - kit of 3	KR-11-K3
20	Drip free diaphragm - kit of 5	KR-115-K5
21	Cup	KR-466-K
22	Complete cup	KR-566-1-B
23	Circlip	25746-007-K5
24	Seal & Pin Kit (+ SST-8434-K5)	GTI-428-K5
25	Spring	JGV-262-K5

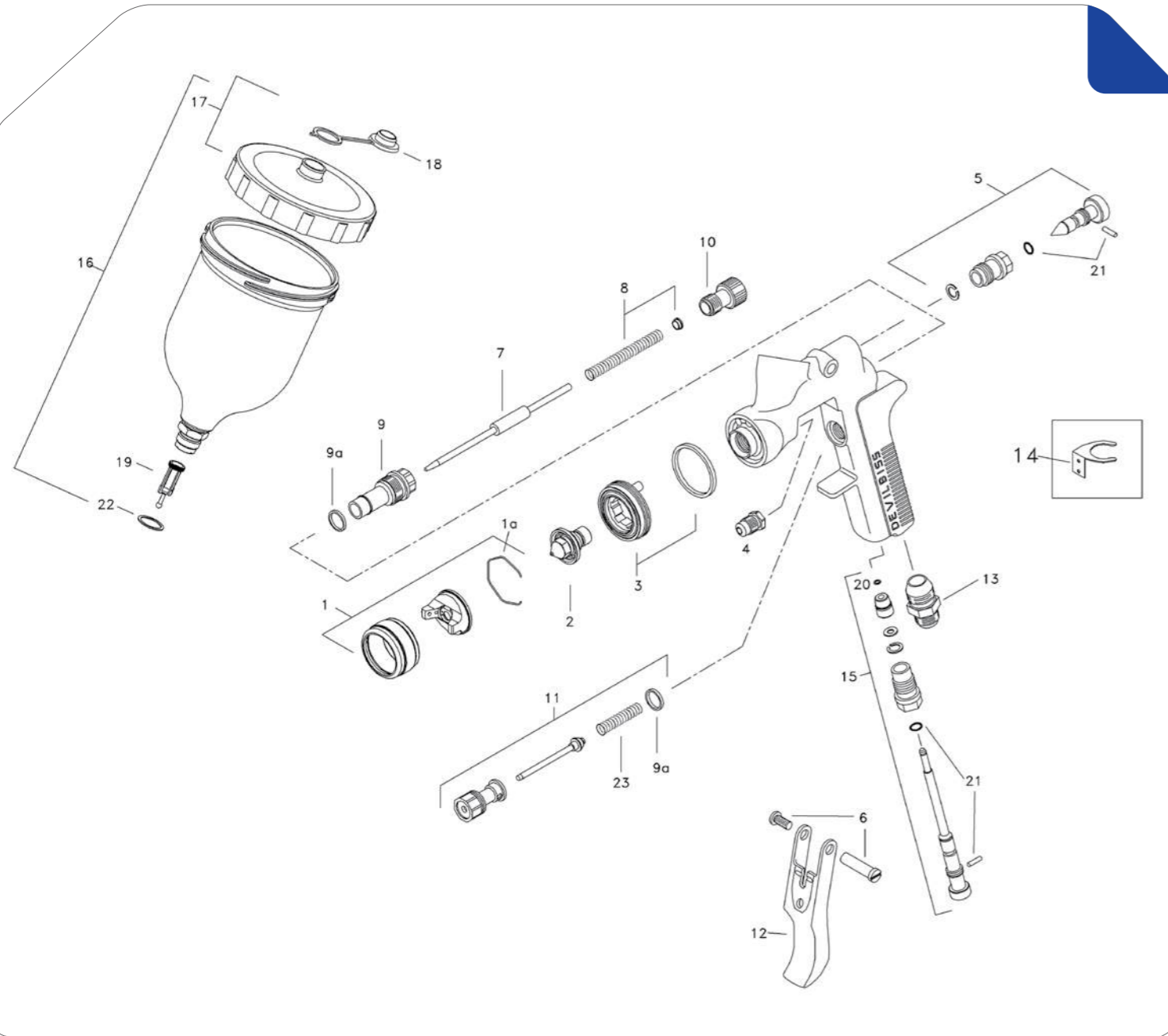

Ref No	Description	Part No
1	Air Cap/Retaining ring * = 186 or 30	AV-4239-**
1a	Spring Clip	JGA-156-K5
2	Tip (* = EX-1.8mm, FF-1.4mm, FW-1.6mm)	AV-645-*
3	Baffle & Seal	JGD-402-K
4	Packing (kit of 2)	GTI-445-K2
5	Spreader Valve	GTI-404-K
6	Stud and Screw	GTI-408-K5
7	Needle (* = DEX or FF)	JGA-421-*K
8	Spring	GTI-409-K5
9	Bushing	JGA-17
9a	Seal - kit of 5	JGS-72-K5
10	Needle Adjusting Screw	GTI-414-K
11	Valve Assembly	JGK-449-K

12	Trigger	GTI-108
13	Connector 1/4	JGA-158
14	Gun Hook	GFG-6
15	Airflow Valve	GTI-415-K
16	1/2 Ltr Gravity Cup Kit	GFC-501
17	Cup Lid	GFC-402
18	Drip Check Lid kit of 5	GFC-2-K5
19	Filter	KGP-5-K5
20	Circlip	25746-007-K5
21	Seal & Pin Kit	GTI-428-K5
22	Washer	GFC-17-K5
23	Spring	JGV-262-K5

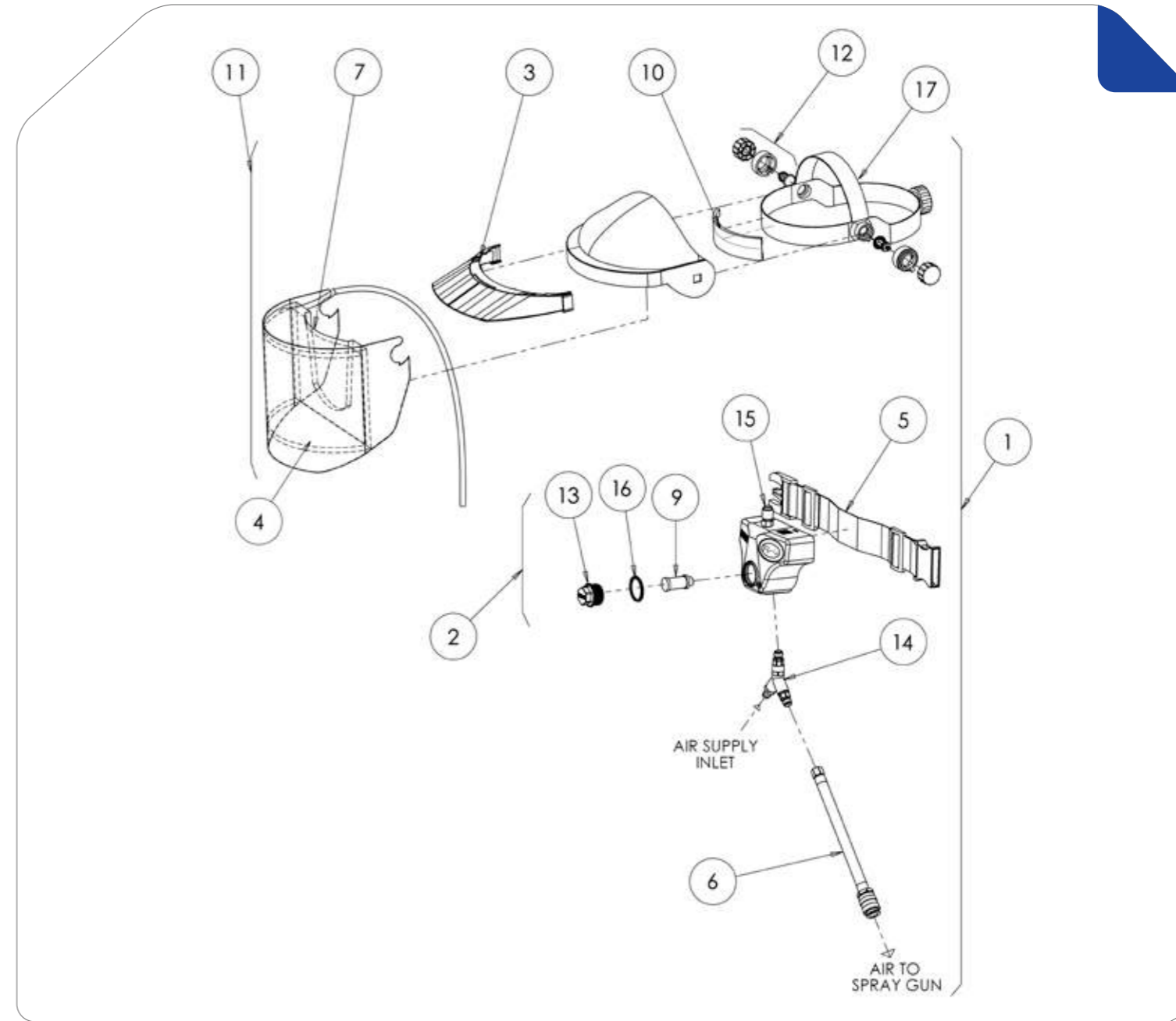

Ref No	Description	Part No
1	Pro Visor complete unit	-
2	Belt & Regulator	PROV-20-K
3	Peak	PROV-21-K
4	Tear-off visors pack of 10	PROV-22-K10
	Tear-off visors pack of 50	PROV-22-K50
5	Belt and buckle assembly	PROV-51-K
6	1.2m Hose (To Spray Gun)	PROV-406-K
7	Rigid acetate visor face seal and air tube	PROV-25-K
8	Storage bag	PROV-26-K
9	Filter element (pack of 4)	PROV-27-K4
10	Lint-free brow band kit	PROV-52-K2
11	Visor head piece & breathing air tube	PROV-29-K

12	Spacer, stud & knob (set of all sizes)	PROV-30-K
13	Filter cap & seal	PROV-31-K
14	Y-Piece Assembly	PROV-32-K
15	Connector	PROV-33-K
16	Filter Cap Seal	PROV-34-K-K4
17	Adjustable headpiece kit	PROV-40-K

HOSES

10m Air hose - 5/16"ID male & female QD's	PRO-415-1
10m Air hose - 5/16"ID	GTI-428-K5

SPRAY GUN SET UP SELECTOR: Gun Inlet Pressure 2.0 bar or as stated

Category	Material	GPG	DVI Base	DVI Clear	Gti Pro Lite	Sri Pro Smart
Polyester	799R VOC Spray Putty	PR10-2.0-2.5				
	PS1900 Transparent Sealer	PR10-1.3-1.4			TE20-13-1.4	
Primers	635R Chromate Free Etching Primer	PR10-1.3-1.4			TE20-13-1.4	TE5-0.8-1.0
	825R Chromate Free Wash Etching Primer	PR10-1.3-1.4			TE20-13-1.4	TE5-0.8-1.0
	901R-907R 2K Plastic Primer Surfacer	PR10-1.3-1.4			TE20-13-1.4	TE5-0.8-1.0
	UV PS140 UV-A Primer Surfacer	UV1-UV2				
Surfacers	1051R-1057R High Productive Surfacer	PR10-1.6-1.8				TE5-1.0-1.2
	PS1061-PS1064-PS1067 Cromax Pro Surfacer	PR10-1.6-1.8				TE5-1.0-1.2
	PS1081-PS1084-PS1087 Energy Surfacer	PR10-1.3-1.4			TE20-1.3	TE5-1.0-1.2
Non standing Primer	NS2081-NS20184 Ultra Performance	PR10-1.3-1.4			TE20-1.3-1.4	
	Centari 5035 Low Emission 2K Topcoat				TE20-1.3-1.4	TE5-1.0-1.2
Solventborne Basecoat	Centari 6000 Low Emission Basecoat		B+1.2-1.3		TE20-1.2-1.3	
	Centari 600 Basecoat Laquer		B+1.2-1.3		TE20-1.2-1.3	
Waterborne Basecoat	Cromax Waterbourne Basecoat		B+1.2-1.3		TE20-1.2-1.3	TE5-HV5-1.0-1.2
	Cromax Pro Waterbourne Basecoat		B+1.2-1.3		TE20-1.2-1.3	TE5-1.0-1.2
Clearcoats	37505-37605 Ultra Productive VOC Clear			CI-1.2-1.3	TE20-1.2-1.3	TE5-1.0-1.2
	CC6300 VOC Protect Clear			CI-1.2-1.3	TE20-1.2-1.3	TE5-1.0-1.2
	CC6400 Standard VOC Clear			CI-1.2-1.3	TE20-1.2-1.3	TE5-1.0-1.2
	CC6600 Cromax Pro Star Clear			CI-1.2-1.3	TE20-1.2-1.3	TE5-1.0-1.2
	CC6700 Ultra Performance Energy Clear			CI-1.2-1.3	TE20-1.2-1.3	TE5-1.0-1.2
	38005 Chroma Clear VOC			CI-1.2-1.3	TE20-1.2-1.3	TE5-1.0-1.2
	CC6500 High Performance VOC Clear			CI-1.2-1.3	TE20-1.2-1.3	TE5-1.0-1.2
	VR-1120 Valueclear VOC			CI-1.2-1.3	TE20-1.2-1.3	TE5-1.0-1.2

Binks +44 1202 571111
marketing-eu@binks.com

DeVilbiss® is a registered trademark of Binks. Models and specifications subject to change without notice. All rights reserved.

DeVilbiss® is a registered trademark of Binks. Models and specifications subject to change without notice. All rights reserved.

Binks +44 1202 571111
marketing-eu@binks.com

SPRAY GUN SET UP SELECTOR: Gun Inlet Pressure 2.0 bar or as stated

Category	Material	GPG	DVI Base	DVI Clear	Gti Pro Lite	Sri Pro Smart
Polyester	Valspar 680 Filler	PR10-2.0-2.5				
	De Beer 1-15 Washprimer	PR10-1.3-1.4				
Primers	De Beer 8-145 surfacer Grey/White/Black	PR10.1.6-1.8				
	DeBeer 1-75 Epoxy White/Grey	PR10.1.6-1.8				
	DeBeer 8-149 HS Tinting Surfacer	PR10.1.6-1.8				
Surfacers	DeBeer 8-149 HS Tinting Surfacer	PR10-1.6-1.8				
Non standing Primer	DeBeer 30-746 HS Non Sanding Filler	PR10-1.3-1.4			TE20-1.3-1.4	
	DeBeer 8-746 Non Sanding Primer	PR10-1.3-1.4			TE20-1.3-1.4	
2K Direct Glass	DeBeer MM2000 Series	PR10-1.3-1.4			TE20-1.3-1.4	TE5-1.0-1.2
	DeBeer MM3000 Series					
Solventborne Basecoat	DeBeer MM500-5999		B+1-1.2-1.3		TE20-1.3-1.4	TE5-1.0-1.2 HV5-1.0-1.2
	DeBeer MM900+		B+1-1.2-1.3		TE20-1.2-1.3	TE5 1.0-1.2 HV5-1.0-1.2
Waterborne Basecoat						
Clearcoats	DeBeer 8-114 Scratch Resistant Repair Clear			CI-1.2-1.3	TE20-1.2-1.3 TT10-1.2-1.3	TE5 1.0-1.2
	DeBeer 8-214 Scratch Resistant Clear			CI-1.2-1.3	TE20-1.2-1.3 TT10-1.2-1.3	TE5 1.0-1.2
	DeBeer 8-514 Speed Clear			CI-1.2-1.3	TE20-1.2-1.3 TT10-1.2-1.3	TE5 1.0-1.2
	DeBeer 8-614 HS 420 Airdry			CI-1.2-1.3	TE20-1.2-1.3 TT10-1.2-1.3	TE5 1.0-1.2
	DeBeer 8-615 HS 420 Airdry Clearcoat HT			CI-1.2-1.3	TE20-1.2-1.3 TT10-1.2-1.3	TE5 1.0-1.2
	DEBeer 1-204/1-102/103			CI-1.2-1.3	TE20-1.2-1.3 TT10-1.2-1.3	TE5 1.0-1.2
	DeBeer 8-714 HS 420supreme Clearcoat			CI-1.2-1.3	TE20-1.2-1.3 TT10-1.2-1.3	TE5 1.0-1.2
	DeBeer 8-414 HS420 Clearcoat			CI-1.2-1.3	TE20-1.2-1.3 TT10-1.2-1.3	TE5 1.0-1.2

SPRAY GUN SET UP SELECTOR: Gun Inlet Pressure 2.0 bar or as stated

Category	Material	GPG	DVI Base	DVI Clear	Gti Pro Lite	Sri Pro Smart
Etch Primer	1k Etch Primer	PR10-1.3-1.4				TE5-0.8-1.0
	2K Universal Plastic Primer	PR10-1.6-2.0				
	Filler 4100	PR10-1.6-2.0				
Primers	Filler 6100 (sanding)					
Non standing Primer	Filler 6100 Non Sanding	PR10-1.3-1.4			TE10-1.3-1.4	TE5-0.8-1.0
2K Direct Gloss	2K topcoat 420				TE10-1.2-1.3 TE20-1.2-1.4	TE-0.8-1.2
Solventborne Basecoat	Basecoat Waterborne		DVI-B 1.2-1.3			TE5-0.8-1.0 HV5-0.8-1.0
						TE10-1.3 HV30-1.3@1.8 Bar
Basecoat	Clear 9000			CI-1.2	TE10-1.2-1.3 TE20-1.2-1.3	TE5-0.8-1.0
	Clear6000AS			CI-1.2	TE10-1.2-1.3 TE20-1.2-1.3	TE5-0.8-1.0
	Clear Matt			CI-1.2	TE10-1.2-1.3 TE20-1.2-1.3	TE5-0.8-1.0
Clearcoats	Clear UHS Speed			CI-1.2	TE10-1.2-1.3 TE20-1.2-1.3	TE5-0.8-1.0

Binks +44 1202 571111
marketing-eu@binks.com

DeVilbiss® is a registered trademark of Binks. Models and specifications subject to change without notice. All rights reserved.

DeVilbiss® is a registered trademark of Binks. Models and specifications subject to change without notice. All rights reserved.

Binks +44 1202 571111
marketing-eu@binks.com

SPRAY GUN SET UP SELECTOR: Gun Inlet Pressure 2.0 bar or as stated

Category	Material	GPG	DVI Base	DVI Clear	Gti Pro Lite	Sri Pro Smart
Polyester	Polyfan Rush 04210	PR10-2.5				
	Green Tech MF602/MF606/MF610	PR10-1.6				
	Green TI 04001/04004/04007/04109	PR10-1.6/1.8				
Primers						
Surfcers						
Non standing Primer	Autolevel MF302/MF306/MF310	PR10 1.4			TE20-13-14	
2K Direct Gloss	MAC1 (M1000)/MAC41 (M4001)	PR10 1.4			TE20-13-14	TE5 1.0/1.2 @ 1.5 BAR
	BSB Solventbourne	B+ 1-1.2-1.3			TE20-13-14	TE5 1.0/1.2 @ 1.5 BAR
Solventborne Basecoat						
Waterborne Basecoat	Hydrofan	B+ 1-1.2-1.3			TE20-12-1.3	TE5 1.0/1.2 @ 1.5 BAR
Clearcoats	Macrofan Airtech MA380				TE20 12-1.3 TI10 12-1.3	TE5 1.0/1.2 @ 1.5 BAR
	Macrofan HS2000 MATT 09890				TE20 12-1.3	TE5 1.0/1.2 @ 1.5 BAR
	Macrofan Power UHS Clearcoat MC 405				CI-1.2-1.3 TE20 12-1.3	TE5 1.0/1.2 @ 1.5 BAR
	Macrofan Plus UHS Clearcoat MC421				CI-1.2-1.3 TE20 12-1.3	TE5 1.0/1.2 @ 1.5 BAR

SPRAY GUN SET UP SELECTOR: Gun Inlet Pressure 2.0 bar or as stated

Category	Material	GPG	DVI Base	DVI Clear	Gti Pro Lite	Sri Pro Smart
Etch Primer	1k Etch Primer	PR10-1.3-1.4				TE5-0.8-1.0
	2K Universal Plastic Primer					
Primers	2K Filler 540 (sanding)	PR10-1.6-2.0				
	2K HS Primer Filler	PR10-1.6-2.0				
	2K Graphite Filler Sanding	PR10-1.6-2.0				
	2K Epoxy Primer	PR10-1.6-2.0				
	2K HB Filler	PR10-1.6-2.0				
	Autosurfacer UV	UV1-UV2				
	1k Multi Plastic Primer	PR10-1.3-1.4				
Non standing	2K Filler 540 Non Sanding	PR10-1.3-1.4				TE5-0.8-1.0
Primer	2K Graphite Filler Non Sanding	PR10-1.3-1.4				TE5-0.8-1.0
2K Direct Gloss	Topcoat				TE10-1.2-1.3 TE10-1.2-1.3 TE20-1.2-1.4	
Solventborne						
Basecoat						
Waterbourne	Basecoat WB GT		DVI-1.2-1.3		TE10-1.3 HV30-1.0-1.8 Bar	TE5-0.8-1.0 HV5-0.8-1.0
Basecoat	2K HS Fast Clear 420		CI-1.2-1.3		TE10-1.2-1.3	TE5-0.8-1.0
	2K HS Premium Clear 420		CI-1.2-1.3		TE10-1.2-1.3	TE5-0.8-1.0
	Multi Matt Clear		CI-1.2-1.3		TE10-1.2-1.3	TE5-0.8-1.0
	2K MS Matting Clear		CI-1.2-1.3		TE10-1.2-1.3	TE5-0.8-1.0
	2K HS Extra Clear		CI-1.2-1.3		TE10-1.2-1.3	TE5-0.8-1.0
Clearcoats	2K Titanium Clear		CI-1.2-1.3		TE10-1.2-1.3	TE5-0.8-1.0
	2K Ultra Air Clear		CI-1.2-1.3		TE10-1.2-1.3	TE5-0.8-1.0

Binks +44 1202 571111
marketing-eu@binks.com

DeVilbiss® is a registered trademark of Binks. Models and specifications subject to change without notice. All rights reserved.

DeVilbiss® is a registered trademark of Binks. Models and specifications subject to change without notice. All rights reserved.

Binks +44 1202 571111
marketing-eu@binks.com

Category	Material	GPG	DVI Base	DVI Clear	Gti Pro Lite	Sri Pro Smart
Polyester	Mipa P60 Spritzfüller	PR10-2.0-2.5				
	Mipa 1k UV Füller	UV1 UV2				
Primers	Aktivprimer Wash Etch	PR10-1.4			TE20 1.3-1.4	
	Haft Promoter 1k Plastic Ferrous Metals				TE20 1.2-1.3	
	Mipa 1k Fast Primer	PR10-1.4			TETE20 1.3-1.4	
Surfacers	EP Primer Epoxy	PR10-1.4-1.8				
	Mipa 4+1 Filler HS	PR10-1.6-1.8				
Non standing	Mipa 2K Multifiller	PR10-1.4-1.6				
	2K HS Express Filler FX4/FX5	PR10-1.4-1.6				
Primer	Mipa 2K HS Filler	PR10-1.4			TE20-13-14	
	Mipa 2K Multifiller Non Sand	PR10-1.3-1.4			TE20-13-14	
2K Direct Gloss	WBS 1k Grundierfüller	PR10-1.3-1.4				
Solventborne	Mipa OC 2K PUR Autolack HS	PR10-1.3-1.4				TE5 1.0/1.2 @1.5 BAR
	Mipa 2K PUR HS					
Basecoat	Mipa BC Basislack	B+ 1.2-1.3				TE5 1.0/1.2 @1.5 BAR
	WBC 2 Schicht Basislack	1.2-1.3 B+				TE5 1.0/1.2 @1.5 BAR
Waterborne Basecoat	Mipa 2K Express Klarlack CX11			CI 1.2-1.3	TE20 1.2-1.3	TE5 1.0/1.2 @ 1.5 BAR
	Mipa 2K HS Klarlack CCM			CI 1.2-1.3	TE20 1.2-1.3	TE5 1.0/1.2 @ 1.5 BAR
	Mipa 2K HS Express Klarlack CX4			CI 1.2-1.3	TE20 1.2-1.3	TE5 1.0/1.2 @ 1.5 BAR
	Mipa 2K HS Klarlack CC9			CI 1.2-1.3	TE20 1.2-1.3	TE5 1.0/1.2 @ 1.5 BAR
	Mipa 2K HS Klarlack CC8			CI 1.2-1.3	TE20 1.2-1.3	TE5 1.0/1.2 @ 1.5 BAR
	Mipa 2K HS Klarlack C75			CI 1.2-1.3	TE20 1.2-1.3	TE5 1.0/1.2 @ 1.5 BAR
	Mipa 2K HS Klarlack C590			CI 1.2-1.3	TE20 1.2-1.3	TE5 1.0/1.2 @ 1.5 BAR

SPRAY GUN SET UP SELECTOR: Gun Inlet Pressure 2.0 bar or as stated

Category	Material	GPG	DVI Base	DVI Clear	Gti Pro Lite	Sri Pro Smart
Polyester	Valspar 680 Filler	PR10-2.0-2.5				
	Octoral PW170 Washprimer	PR10-1.3-1.4				
Primers	Octoral PF-131 Surfacer Grey White Black	PR10-1.6-1.8				
	Octoral PFI32 HS Tinting Surfacer	PR10-1.6-1.8				
	Octoral PFI44HS Non Sanding Filler	PR10-1.4-1.6				
	Octoral PFI131 Surfacer Grey White Black	PR10-1.3-1.4			TE20-1.3-1.4	
Surfacers						
Non standing Primer	Octoral PH254 Non Sanding Primer	PR10-1.3-1.4			TE20-1.3-1.4	
	Octoral PFI44 Non Sanding Filler	PR10-1.3-1.4			TE20-1.3-1.4	TE5-1.0-1.2
2K Direct Gloss	Octocryl Octocryl Hs420	PR10-1.3-1.4			TE20-1.3-1.4	TE5-1.0-1.2
Solventborne Basecoat	Octobase		B+ 1-1.2-1.3		TE20-1.3-1.4	TE5-1.0-1.2 HV5-1.0-1.2
	Octobase Eco Plus		B+ 1-1.2-1.3		TE20-1.3-1.4	TE5 1.0-1.2 HV5-1.0-1.2
Waterborne Basecoat	Octoral C450 Scratch Resistance			CI-1.2-1.3	TE20-1.2-1.3 T110-1.2-1.3	TE5 1.0-1.2
	Octoral C250 Scratch Resistance			CI-1.2-1.3	TE20-1.2-1.3 T110-1.2-1.3	TE5 1.0-1.2
	Octoral CM-267-269			CI-1.2-1.3	TE20-1.2-1.3 T110-1.2-1.3	TE5 1.0-1.2
	Octoral C300 HS400 Speed Clear			CI-1.2-1.3	TE20-1.2-1.3 T110-1.2-1.3	TE5 1.0-1.2
	Octoral C400 HS 420 Airdry Clearcoat			CI-1.2-1.3	TE20-1.2-1.3 T110-1.2-1.3	TE5 1.0-1.2
Clearcoats	Octoral C401 HS Airdry Clearcoat			CI-1.2-1.3	TE20-1.2-1.3 T110-1.2-1.3	TE5 1.0-1.2
	Octoral C240 C60			CI-1.2-1.3	TE20-1.2-1.3 T110-1.2-1.3	TE5 1.0-1.2
	Octoral C500 HS 420 Superb Clearcoat			CI-1.2-1.3	TE20-1.2-1.3 T110-1.2-1.3	TE5 1.0-1.2

Binks +44 1202 571111
marketing-eu@binks.com

DeVilbiss® is a registered trademark of Binks. Models and specifications subject to change without notice. All rights reserved.

DeVilbiss® is a registered trademark of Binks. Models and specifications subject to change without notice. All rights reserved.

Binks +44 1202 571111
marketing-eu@binks.com

*2.0 BAR AT GUN HANDLE / 1.5 BAR AT DIGITAL GAUGE

Category	Material	GPG	DVI Base	DVI Clear	Gti Pro Lite	Sri Pro Smart
Primer	D8092 Universal Etch Primer	PR10-1.3-1.4				TE5-0.8-1.0
	D8010/D8015/D8017 Rapid Greymatic Primer	PR10-1.6-1.8				
Fillers	D8018/D8019/D8024 Greymatic Primer	PR10-1.6-1.8				
Non sanding Primer	D8501/D8505/D8507 HS Wet on Wet Primer	PR10-1.3-1.4				
2K Single Stage	UHS Delttron® Progress				TE10-1.2-1.3 TE20-1.2-1.3	
Waterborne	Basecoat Waterborne Envirobase® High Performance		DVI-B-1.3		TE10-1.2-1.3 HV30-1.2-1.3@1.75 Bar	TE5-0.8-1.0 HV5-0.8-1.0
Clearcoat	Delttron® UHS		DVI-C+-1.2		HV25-1.1-1.2	TE5-0.8-1.0

SPRAY GUN SET UP SELECTOR: Gun Inlet Pressure 2.0 bar or as stated

Category	Material	GPG	DVI Base	DVI Clear	Gti Pro Lite	Sri Pro Smart
Etch Primer	Washprimer 1K CF 2K Plastic Primer	PR10-1.3-1.4			TE10-1.2-1.3	TE5-0.8-1.2
	1K All Plastics Primer	PR10-1.6-2.0			TE10-1.2-1.3	
Primers	ColourBuild Plus Sanding	PR10-1.6-2.0				
	AutosurfacerRapid	PR10-1.6-2.0				
	Autosurfacer HB	PR10-1.6-2.0				
	Autosurfacer EPI1	PR10-1.6-2.0				
	Autosurfacer UV	UV1-UV2				
Surfacers						
Non standing Primer	Colourbuild Plus Non Sanding	PR10-1.3-1.4			TE10-1.3-1.4	TE5-0.8-1.2
2K Direct Gloss	Autocryl Plus LV MM				TE10-1.3	TE5-0.8-1.2
Solventborne Basecoat						
Waterbourne Basecoat	Atowave MM 2.0		DV1-1.2-1.3		TE10-1.3	TE5-0.8-1.0 HV5-0.8-1.0
Basecoat						
Clearcoats	Autoclear LV Exclusive			CI-1.2	TE10-1.2-1.3	TE5-0.8-1.2
	Autoclear LV Superior			CI-1.2	TE10-1.2-1.3	TE5-0.8-1.2
	Autoclear Mix and Matt			CI-1.2	TE10-1.2-1.3	TE5-0.8-1.2
	Autoclear UV			CI-1.2	TE10-1.2-1.3	TE5-0.8-1.2
	Autoclear WB			CI-1.2	TE10-1.2-1.3	TE5-0.8-1.2
	Autoclear 2.0			CI-1.2	TE10-1.2-1.3	TE5-0.8-1.2
	Autoclear Aerodry			CI-1.2	TE10-1.2-1.3	TE5-0.8-1.2
				CI-1.2	TE10-1.2-1.3	TE5-0.8-1.2
				CI-1.2	TE10-1.2-1.3	TE5-0.8-1.2
				CI-1.2	TE10-1.2-1.3	TE5-0.8-1.2

Binks +44 1202 571111
marketing-eu@binks.com

DeVilbiss® is a registered trademark of Binks. Models and specifications subject to change without notice. All rights reserved.

DeVilbiss® is a registered trademark of Binks. Models and specifications subject to change without notice. All rights reserved.

Binks +44 1202 571111
marketing-eu@binks.com

SPRAY GUN SET UP SELECTOR: Gun Inlet Pressure 2.0 bar or as stated

Category	Material	GPG	DVI Base	DVI Clear	Gti Pro Lite	Sri Pro Smart	
Polyester	Raderal Spray Polyester 3508	PR10-2.0-2.5					
	Permafleet Transparent Sealer	PR10-1.3-1.4			TE20-1.3-1.4		
	Priomat 1k Primer 4085	PR10-1.3-1.4			TE20-1.3-1.4	TE5-0.8-1.0	
Primers	Priomat Wash Primer 4075	PR10-1.3-1.4			TE20-1.3-1.4	TE5-0.8-1.0	
	Priomat Elastic Primer 3300	PR10-1.3-1.4			TE20-1.3-1.4	TE5-0.8-1.0	
	Permasolid 1k UV-A Primer 9002	UV1-UV2					
Surfacers	Permasolid HS Express Surfacer 5250	PR10-1.6-1.8				TE5-1.0-1.2	
	Permasolid Performance Surfacer 5320	PR10-1.4-1.8				TE5-1.0-1.2	
	Permasolid HS Speed Surfacer 5550	PR10-1.3-1.4			TE20-1.3	TE5-1.0-1.2	
Non standing Primer	Permasolid HS WOW Speed Surfacer 5550	PR10-1.3-1.4			TE20-1.3-1.4		
	Permasolid HS Vario Surfacer 5340	PR10-1.3-1.4			TE20-1.3-1.4		
2K Direct Gloss	Permasolid 275 Series				TE20-1.3-1.4	TE5-1.0-1.2	
Solventborne Basecoat	Permacron 293/295 Series		B+1.2-1.3		TE20-1.2-1.3		
Waterborne Basecoat	Pemahyd 280/285		B+1.2-1.3		TE20-1.2-1.3	TE5-HV5-1.0-1.2	
	Pemahyd Hi-Tec 480		B+1.2-1.3		TE20-1.2-1.3	TE5-1.0-1.2	
Clearcoats	Permasolid HS Optimum Plus Clearcoat 8650			CI-1.2-1.3	TE20-1.2-1.3	TE5-1.0-1.2	
	Permasolid HS Diamond Clear 8450			CI-1.2-1.3	TE20-1.2-1.3	TE5-1.0-1.2	
	Permasolid HS Clearcoat 8034			CI-1.2-1.3	TE20-1.2-1.3	TE5-1.0-1.2	
	Permasolid HS Clearcoat 8055			CI-1.2-1.3	TE20-1.2-1.3	TE5-1.0-1.2	
	Permasolid HS Speed Clear 8800			CI-1.2-1.3	TE20-1.2-1.3	TE5-1.0-1.2	
	Permasolid Race Clear 8700			CI-1.2-1.3	TE20-1.2-1.3	TE5-1.0-1.2	
	Permatfast Clear 8007			CI-1.2-1.3	TE20-1.2-1.3	TE5-1.0-1.2	
					CI-1.2-1.3	TE20-1.2-1.3	TE5-1.0-1.2
					CI-1.2-1.3	TE20-1.2-1.3	TE5-1.0-1.2
					CI-1.2-1.3	TE20-1.2-1.3	TE5-1.0-1.2

SPRAY GUN SET UP SELECTOR: Gun Inlet Pressure 2.0 bar or as stated

Category	Material	GPG	DVI Base	DVI Clear	Gti Pro Lite	Sri Pro Smart
Polyester	U100 Standox Sprayfiller	PR10-2.0-2.5				
	U2500 Standox 2K Sealer Transparent	PR10-1.3-1.4			TE20-1.3-1.4	
	U3100 Etching Adhesion Primer	PR10-1.3-1.4			TE20-1.3-1.4	TE5-0.8-1.0
	U3010 1KPrimer Filler	PR10-1.3-1.4			TE20-1.3-1.4	TE5-0.8-1.0
Primers	U32200 Plastic Primer Surfacer	PR10-1.3-1.4			TE20-1.3-1.4	TE5-0.8-1.0
	U7120 Standoflash UV-A Filler	UV1-UV2				
	U7530 VOC Pro Filler	PR10-1.6-1.8				TE5-1.0-1.2
Surfacers	U7560 VOC Xtra Filler	PR10-1.4-1.8				TE5-1.0-1.2
	U7600 VOC Extreme Filler	PR10-1.3-1.4			TE20-1.3	TE5-1.0-1.2
Non Standing Primer	U7650 VOC Extreme WOW Filler	PR10-1.3-1.4			TE20-1.3-1.4	
2K Direct Gloss	U7580 VOC Non Stop Primer Surfacer	PR10-1.3-1.4			TE20-1.3-1.4	TE5-1.0-1.2
Solventborne Basecoat	Standocryl VOC 2k					
	Standox Basecoat		B+1.2-1.3		TE20-1.2-1.3	
Waterborne Basecoat	Standohyd Plus Basecoat		B+1.2-1.3		TE20-1.2-1.3	TE5-HV5-1.0-1.2
	Standobleue Basecoat		B+1.2-1.3		TE20-1.2-1.3	TE5-1.0-1.2
	K9530 VOC Express Clear			CI-1.2-1.3	TE20-1.2-1.3	TE5-1.0-1.2
Clearcoats	K9570 Platinum Clear			CI-1.2-1.3	TE20-1.2-1.3	TE5-1.0-1.2
	VOC 2K Clearcoat			CI-1.2-1.3	TE20-1.2-1.3	TE5-1.0-1.2
	K9560 VOC Xtra Clear			CI-1.2-1.3	TE20-1.2-1.3	TE5-1.0-1.2
	K9580 VOC Extreme Clear			CI-1.2-1.3	TE20-1.2-1.3	TE5-1.0-1.2
	K9590 VOC Performance Clear			CI-1.2-1.3	TE20-1.2-1.3	TE5-1.0-1.2
	K9590 VOC Easy Clear			CI-1.2-1.3	TE20-1.2-1.3	TE5-1.0-1.2

Binks +44 1202 571111
marketing-eu@binks.com

DeVilbiss® is a registered trademark of Binks. Models and specifications subject to change without notice. All rights reserved.

Binks +44 1202 571111
marketing-eu@binks.com

DeVilbiss® is a registered trademark of Binks. Models and specifications subject to change without notice. All rights reserved.

Category	Material	GPG	DVI Base	DVI Clear	Gti Pro Lite	Sri Pro Smart
Polyester	No Product Offered					
	S2000 Wash Primer					
	S2500 Plastic Adhesion Promoter					
Primers						
Surfacers	S3020/S3060 Sanding Surfacer					
Non Standing Primer	S3020/S3060 Non Sand Surfacer					
2K Direct Gloss	No Product Offered					
Solventborne Basecoat	No Product Offered					
WaterBorne Basecoat	Syrox Basecoat					
Clearcoats	S5000 HS Top Clear					
	S5100 Air Dry Clear					
	S5200 Flex Clear					

CONDITIONS OF SALE

BINKS U.K. LTD (“BINKSUK”)

1. INTERPRETATION

1.1 In these Conditions:

- Business Day:** a day (other than a Saturday, Sunday or public holiday) when banks in London are open for business.
- Buyer:** Is the person who accepts BINKSUK’s quotation or whose order is accepted by BINKSUK.
- Conditions:** Are these conditions of sale and (unless the context otherwise requires) includes any special terms on the face of BINKSUK’s quotation or acceptance of the Buyer’s order.
- Contract:** Is the contract for the purchase and sale of the Goods and/or supply of services.
- Goods:** Are the goods which BINKSUK is to supply.

2. BASIS OF THE SALE

- 2.1. Subject to BINKSUK’s quotation, all Goods are sold and services supplied subject to these Conditions to the exclusion of any other terms and conditions.
- 2.2. No variation to these Conditions shall be binding unless agreed in writing by a general manager of BINKSUK.
- 2.3. BINKSUK’s employees or agents are not authorised to make any representations unless confirmed by BINKSUK in writing. The Buyer acknowledges that it does not rely on, and irrevocably waives any claim it may have for damages for or the right to rescind the Contract for any such representations which are not so confirmed (unless such representations were fraudulently made).
- 2.4. Any advice or recommendation given by BINKSUK or its employees or agents to the Buyer or its employees or agents which is not confirmed in writing by BINKSUK is followed or acted upon entirely at the Buyer’s own risk and BINKSUK shall not be liable for any such advice or recommendation which is not so confirmed.
- 2.5. Any typographical, clerical or other error or omission in any sales literature, quotation, price list, acceptance of offer, invoice or other document or information issued by BINKSUK shall be subject to correction without any liability on the part of BINKSUK.

3. ORDERS AND SPECIFICATIONS

- 3.1. Quotations are valid for 60 days only. No order submitted by the Buyer shall be deemed to be accepted by BINKSUK unless and until confirmed in writing by BINKSUK.
- 3.2. The Buyer is responsible for ensuring the accuracy of the terms of any order and for giving BINKSUK any necessary information within a sufficient time to enable BINKSUK to perform the Contract.
- 3.3. The quantity and description of and any specification for the Goods or services shall be those set out in BINKSUK’s quotation (if accepted by the Buyer) or BINKSUK’s acceptance of the Buyer’s order.
- 3.4. BINKSUK reserves the right to make any changes in the specification of the Goods (including materials and components) which are required to conform with any applicable law or, which do not materially affect their quality or performance.
- 3.5. An order once accepted by BINKSUK may only be cancelled with its written agreement and the Buyer shall indemnify BINKSUK in full against all loss (including loss of profit), costs (including labour and materials) and damages incurred by BINKSUK.

4. DRAWINGS AND SPECIFICATIONS

- 4.1. Any specifications or drawings supplied remain BINKSUK’s sole property and are subject to recall at any time before BINKSUK’s quotation is accepted. Any drawings supplied are not to be used for construction purposes. Where BINKSUK’s quotation includes a drawing reference, copy of any approved prints or equipment data sheets, these must be signed by the Buyer and must accompany the equipment purchase order.
- 4.2. Before signing the prints the Buyer shall check equipment size, location of building, and all interferences as shown on the drawings, data sheets etc and clearances and note clearly and comprehensively any changes or interferences on the prints.
- 4.3. If Goods are to be made or any process is to be applied in accordance with a specification, drawing or design submitted by the Buyer, the Buyer shall indemnify BINKSUK against all loss, damages, costs and expenses awarded against or incurred by BINKSUK in connection with or paid or agreed to be paid by BINKSUK in settlement of any claim for infringement of any third party rights which results from BINKSUK’s use of such material.
- 4.4. If any claim is made against the Buyer that the Goods supplied or their proper use infringe the intellectual property rights of any other person, BINKSUK shall indemnify the Buyer against all damages, costs and expenses awarded against the Buyer in connection with the claim provided that:
 - 4.4.1. BINKSUK is given full control of any proceedings or negotiations in connection with any such claim;
 - 4.4.2. the Buyer shall pay to BINKSUK all damages and costs (if any) awarded in favour of the Buyer which are payable by, or agreed with the consent of the Buyer (which consent shall not be unreasonably withheld) to be paid by, any other party in respect of any such claim; and
 - 4.4.3. without prejudice to any duty of the Buyer at common law, BINKSUK may require the Buyer to take such steps as BINKSUK may reasonably require to mitigate or reduce any such loss, damages, costs or expenses for which BINKSUK is liable to indemnify the Buyer under this condition.

5. PREPARATION OF SITE

- 5.1. The Buyer shall obtain all necessary licences, permits and permissions.
- 5.2. The Buyer shall clear the site for installation and make it ready for the reception of the Goods. The Buyer shall keep the site free from water, debris and obstructions, and make required alterations to buildings and other equipment if required for the proper clearance and support of the Goods.
- 5.3. The Buyer shall ensure that BINKSUK shall not be delayed by the operations of others (including the Buyer) or the Buyer’s failure to provide the conditions and facilities required. If such delays cause extra visits by BINKSUK, these will be charged in addition.
- 5.4. The Buyer shall, at its own risk, unload the Goods and store them close to the point of erection, provide safe and convenient storage room for tools and materials, provide adequate work room for BINKSUK personnel, give proper care to and provide insurance against loss by fire and theft for all materials and equipment prior to, during and after installation.

6. INSTALLATION LIABILITY

- 6.1. The Buyer shall provide the necessary foundations required, carry out cutting away and making good, and grouting in foundation bolts etc, and will provide a level concrete floor for the plant of adequate strength. The

- Buyer shall be entirely responsible for the exact siting of the Goods to meet the Buyer’s requirements.
- 6.2. All gas, water, electrical and compressed air services (including interconnecting wiring) shall be provided by the Buyer. All building work such as cutting holes etc for stacks to be undertaken by the Buyer.
 - 6.3. If BINKSUK undertakes any of the work detailed in the previous paragraphs to complete installation, such work shall be charged in addition and BINKSUK shall not be responsible for any consequential damage.

7. PLANT ACCEPTANCE/TAKING OVER

- 7.1. The Goods shall be deemed to have been accepted at the earlier of:
 - 7.1.1. When installation has been completed and the Goods have passed or are deemed to have passed all tests provided for in BINKSUK’s proposal; or
 - 7.1.2. One calendar month after the Goods shall have been put into use.
- 7.2. The time of acceptance shall not be delayed because of additions, minor omissions or defects which do not materially affect the use of the Goods or if the Buyer is preventing BINKSUK from completing the Contract.

8. PRICE

- 8.1. The price shall be BINKSUK’s quoted price (or if a quoted price is no longer valid), the price stated in BINKSUK’s acknowledgement of order. Prices are ex works.
- 8.2. BINKSUK may, by giving notice to the Buyer at any time before delivery, increase the price to reflect any increase in the cost to BINKSUK which is due to any factor beyond the control of BINKSUK.
- 8.3. Any applicable value added tax or other taxes or duties are payable by the Buyer in addition.
- 8.4. Goods for export will be packed in good quality export cases at the Buyer’s cost. Any special packing requirements of the Buyer will attract an additional charge. Packing for parcel post or air freight will be in an appropriately economic manner using cartons and/or parcels.

9. TERMS OF PAYMENT

- 9.1. Payment shall be made in accordance with BINKSUK’s quotation.
- 9.2. BINKSUK may recover the price, notwithstanding that delivery may not have taken place and the property in the Goods has not passed. The time of payment shall be of the essence of the Contract.
- 9.3. BINKSUK may charge the Buyer interest (both before and after any judgement) on the amount unpaid, at the rate of 4 per cent per annum above the base rate from time to time of JP Morgan until payment in full is made.

10. DELIVERY

- 10.1. The method of delivery shall be in accordance with BINKSUK’s quotation. The Buyer must obtain any import or export licences required.
- 10.2. Any dates given for delivery of the Goods or provision of services are approximate only and BINKSUK shall not be liable for any delay howsoever caused. Time for delivery or performance shall not be of the essence.
- 10.3. The Goods may be delivered in instalments. Each delivery shall constitute a separate contract and failure by BINKSUK to deliver any one or more of the instalments in accordance with these Conditions or any claim by the Buyer in respect of any one or more instalments shall not entitle the Buyer to treat the Contract as a whole as repudiated.
- 10.4. If the Buyer fails to take delivery of the Goods or fails to give BINKSUK adequate delivery instructions within 14 days

of their availability BINKSUK may:

- 10.4.1. store the Goods until actual delivery and charge the Buyer for the costs (including insurance) of storage; or
 - 10.4.2. sell the Goods at the best price readily obtainable and (after deducting all storage, selling and other expenses) account to the Buyer for the excess over sums owing by the Buyer or charge the Buyer for any shortfall.
- 10.5. Where BINKSUK arranges forwarding of the Goods, the Buyer shall notify BINKSUK and the carrier in writing within 48 hours of delivery of any damage to the Goods or shortage in delivery.

- 10.6. The Buyer shall inspect the Goods on receipt and notify BINKSUK of any defects within 7 days of delivery failing which the Buyer shall be deemed to have accepted them. After acceptance the Buyer shall not be entitled to reject Goods. The Buyer shall not be entitled to reject the Goods for any defect or failure which is so slight that it would be unreasonable to reject them.

11. RISK AND PROPERTY

- 11.1. Risk in the Goods shall pass to the Buyer when BINKSUK notifies the Buyer that the Goods are available for collection or when the Goods leave BINKSUK’s premises, whichever is the earlier.
- 11.2. Notwithstanding any other provision of these Conditions, the property in the Goods shall not pass to the Buyer until BINKSUK has received in cash or cleared funds payment in full of all sums due under the Contract and all other contracts between the Buyer and BINKSUK (whether or not the sums due under those contracts are immediately due and payable). Until then the Buyer shall:
 - 11.2.1. hold the Goods as BINKSUK’s fiduciary agent and bailee, and shall keep them separate from all other goods and properly stored, protected and insured and identified as BINKSUK’s property but may resell or use the Goods in the ordinary course of its business;
 - 11.2.2. (provided the Goods are still in existence and have not been resold), deliver up the Goods to BINKSUK on demand
 - 11.2.3. and, if the Buyer fails to do so immediately, BINKSUK may enter any premises of the Buyer or any third party where the Goods are stored and repossess the Goods.

12. WARRANTIES AND LIABILITIES

- 12.1. BINKSUK warrants that it holds unencumbered title to the Goods and will perform services with reasonable skill and care.
- 12.2. Subject to condition 12.3, BINKSUK warrants that the Goods will correspond with their specification at the time of delivery and will be free from defects in material and workmanship for 12 months from delivery.
- 12.3. The above warranty does not apply to any defect:
 - 12.3.1. arising from any drawing, design or specification supplied by the Buyer;
 - 12.3.2. arising from fair wear and tear, improper use, storage or installation or maintenance, failure to follow BINKSUK’s instructions (whether oral or in writing), or alteration or repair of the Goods without BINKSUK’s approval;
 - 12.3.3. which is not immediately notified in writing to BINKSUK;
 - 12.3.4. if any sum owing by the Buyer to BINKSUK has not been paid;
 - 12.3.5. in items not manufactured by BINKSUK, when the Buyer shall only be entitled to the benefit of any such warranty as is given to BINKSUK by the

manufacturer.

12.4. BINKSUK shall replace or repair free of charge the Goods (or the part in question) returned to BINKSUK's factory carriage paid which do not meet the warranty in condition 12.2 or, at BINKSUK's sole discretion, refund to the Buyer the price of the Goods (or a proportionate part of the price) but BINKSUK shall have no further liability to the Buyer. The warranty on replacements or repairs shall be to the end of the original warranty period. Repairs and replacements will be delivered free within the UK and to the nearest port or airport c.i.f. outside the UK.

12.5. Subject as expressly provided in these Conditions, all warranties, conditions, representations or other terms implied by statute or common law are excluded to the fullest extent permitted by law.

12.6. The following provisions set out BINKSUK's entire liability whether arising in contract, tort (including negligence), misrepresentation (other than fraudulent misrepresentation) or otherwise howsoever arising.

AND THE BUYER'S ATTENTION IS IN PARTICULAR DRAWN TO THE FOLLOWING PROVISIONS OF THIS CONDITION

12.7. To the extent the law does not permit such liability to be excluded:

12.7.1. BINKSUK's liability to the Buyer for death or injury resulting from its negligence shall not be limited;

12.7.2. BINKSUK accepts liability to the Buyer for damage to the tangible property of the Buyer resulting from the negligence of BINKSUK not exceeding £1,000,000 for any one incident or series of incidents arising from a common cause;

12.7.3. Save as otherwise expressly provided, BINKSUK's entire liability shall be limited to damages of an amount equal to the price due under the Contract.

12.8. Subject to condition 12.7.1 above, BINKSUK shall not be liable for any increased costs, expenses, loss of profits, goodwill, business, contracts, revenues or anticipated savings or any type of special indirect or consequential loss (including loss or damage suffered by the Buyer as a result of a claim by a third party) even if such loss was reasonably foreseeable or BINKSUK had been advised of the possibility of the Buyer incurring the same.

12.9. BINKSUK shall not be liable to the Buyer or be deemed to be in breach of the Contract by reason of any delay in performing, or any failure to perform, any of BINKSUK's obligations, if the delay or failure was due to any cause beyond BINKSUK's reasonable control including (without limitation) flood, fire, accident, transportation delays, strikes, war or threat of war, sabotage, civil disturbance or governmental action, disruption of supplies or services.

12.10. Save as otherwise expressly provided, the Buyer shall indemnify BINKSUK against any cost, claim, expense, loss or liability made by any person in connection with the Goods or their use.

13. INSOLVENCY AND BREACH

13.1. If the Buyer fails to make any payment when due or breaches any provision of the Contract; or BINKSUK reasonably apprehends that the solvency of the Buyer may be in jeopardy BINKSUK may cancel the Contract or suspend any further deliveries under the Contract without any liability to the Buyer, and if the Goods have been delivered but not paid for the price shall become immediately due and payable notwithstanding any previous agreement or arrangement to the contrary.

14. SAFETY, OPERATING AND MAINTENANCE INSTRUCTIONS

The Buyer's attention is directed to the instructions for use and cautionary notes supplied with the Goods, as well as other technical literature.

15. STANDARD OF COATING ATTAINED

The Buyer shall follow BINKSUK's instructions on operation

and maintenance. BINKSUK accepts no responsibility for unsatisfactory results due to use of coating materials not recommended in writing by BINKSUK or whose composition or quality when supplied is different from that tested by BINKSUK when giving its recommendation.

16. GENERAL

16.1. BINKSUK may assign its rights and obligations. The Buyer may not assign its rights and obligations.

16.2. Any notice shall be in writing addressed to the addressee at its registered office or principal place of business or such other address as may have been notified by the party giving the notice.

16.3. Any notice is deemed to have been received:

16.3.1. if delivered personally, at the time of delivery; or

16.3.2. if sent by commercial courier, at the time of signature of the courier's delivery receipt; or

16.3.3. in the case of pre-paid first class post or recorded delivery, 9.00 am on the second Business Day after posting; or

16.3.4. in the case of airmail, 9.00 am on the fifth Business Day after posting.

16.4. No delay or failure by BINKSUK in enforcing or partially enforcing any provision of the Contract shall constitute a waiver of that provision or any other provision. No waiver by BINKSUK shall be considered as a waiver of any subsequent breach of the same or any other provision. No waiver by BINKSUK shall be effective unless in writing.

16.5. If any provision of these Conditions is held by any competent authority to be invalid or unenforceable in whole or in part the validity of the other provisions of these Conditions and the remainder of the provision in question shall not be affected.

16.6. These Conditions constitute the entire agreement between BINKSUK and the Buyer concerning the supply of the Goods and replace and supersede any prior arrangement, understanding, warranty or representation (other than any fraudulent misrepresentation).

16.7. BINKSUK's rights are cumulative and in addition to any rights available to it at common law.

16.8. The Contract shall be governed by the laws of England and Wales and, subject to clause, 16.9 the parties submit to the exclusive jurisdiction of the courts of England and Wales. For the avoidance of doubt, the United Nations Convention on the International Sale of Goods shall not apply to the Contract.

16.9. Nothing in these Conditions shall limit the right of BINKSUK to take proceedings against the Buyer in any other court of competent jurisdiction, nor shall the taking of proceedings in any one or more jurisdiction preclude the taking of proceedings in any other jurisdiction, whether concurrently or not, to the extent permitted by the law of such other jurisdiction.

16.10. No term of this contract shall be enforceable under the Contracts (Rights of Third Parties) Act 1999 by a third party.

16.11. These Conditions are drafted in the English language. If these Conditions are translated into any other language, the English language text shall prevail.

16.12. Any notice given under or in connection with the Contract shall be in the English language. All other documents provided under or in connection with the Contract shall be in the English language.

A guide to the DSEAR and ATEX Directives

What is DSEAR and ATEX?

The EU Directives 2014/34/EU(ATEX) "Equipment for use in potentially explosive atmospheres" and the "Workplace directive" 1999/92/EC (ATEX 137) are the European directives, which ensure employers work practices and manufacturers of equipment used in potentially explosive atmospheres, are safe and do not create potential explosion hazards. In other words, its all about health and safety at work for workers who handle and work with flammable and dangerous materials, to ensure they are not at risk of an explosion from the equipment and work practices.

The ATEX directives are implemented into UK law by the regulations "Dangerous Substances and Explosive Atmospheres Regulations" known as DSEAR 2002 and "the Equipment and protective systems for use in potentially explosive atmospheres regulations" 1996. DSEAR became mandatory

in July 2006. DSEAR is a legal Health and Safety requirement which is enforced by the HSE, local authorities and in part the fire service.

ATEX Compliance

As a manufacturer of equipment used in potentially explosive atmospheres, we comply with this directive by applying the CE mark along with the Explosion protection symbol  and other markings to show compliance of that product.

Each piece of equipment must be marked with information to enable the user to assess its suitability to be used in the environment it is intended to be used in. The equipment could be marked with the following;

- Name and address of Manufacturer
- The CE mark
- If the equipment has been certified by a Notified Body, their reference follows the CE mark
- Equipment model number/name/type
- Year of manufacture
- The Explosion protection Symbol 
- The equipment Group II and category 1, 2 or 3
- For Gas (G) e.g. Group 2, Cat 2 Gas

Workplace regulations DSEAR 2002

The ATEX 1999/92/EC workplace regulations are implemented in the UK through the DSEAR 2002 Regulations. The duties for employers and owners under DSEAR are;

- Carry out a risk assessment of work involving dangerous substances and eliminate or reduce any risks identified.
- Provide equipment and procedures for accidents and emergencies.
- Instruct and train employees.
- Areas where hazardous explosive atmospheres may occur are classified into zones and where necessary marked with a specified "EX" sign at their points of entry; (eg spray booths, mix rooms, paint stores etc).
- Provide equipment and protective systems which comply with ATEX Regulations appropriate for the Zone rating of the hazardous area.
- Document all the above in an Explosion Protection Document.

Avoidance of Hazards associated with Spraying flammable materials

The main hazard with spraying is electrostatic discharges and mechanically generated sparks. To avoid these ignition hazards, you should;

- Only use equipment CE marked to ATEX regulations. Most Carlisle Fluid Technologies UK Ltd Products are CE marked to ATEX eg Sprayguns, Digital Gauge, hoses. If in doubt, contact your distributor or Carlisle Fluid Technologies UK Ltd.
- The equipment must be installed and used in accordance with the instructions provided by the manufacturer(s).
- Ensure metallic parts of the equipment are earthed and bonded together (e.g. pressure feed tanks and pumps) to avoid potential differences between them. Metallic portable containers must be bonded and earthed. Check earth continuity at regular intervals. Keep earthing points clean.
- Use conductive air and fluid hoses to avoid static charging from air and fluid flows.
- Equip Operators with anti-static clothing and conductive footwear. Remove contaminated clothing if leaving the workplace into areas where ignitions hazards may occur e.g. smoking.
- Clean equipment with non-flammable liquids, or use safety cans with flame arrestors for use with flammable liquids.
- Removal of paint residues with scrapers made of plastic or non-sparking materials (steel scrapers can create sparks). Coat walls with strippable/peelable coatings to avoid removal of residues by mechanical means.

More information can be found at the HSE DSEAR website: <http://www.hse.gov.uk/fireandexplosion/dsear.htm>

Typical Markings found on Hazardous Area Equipment

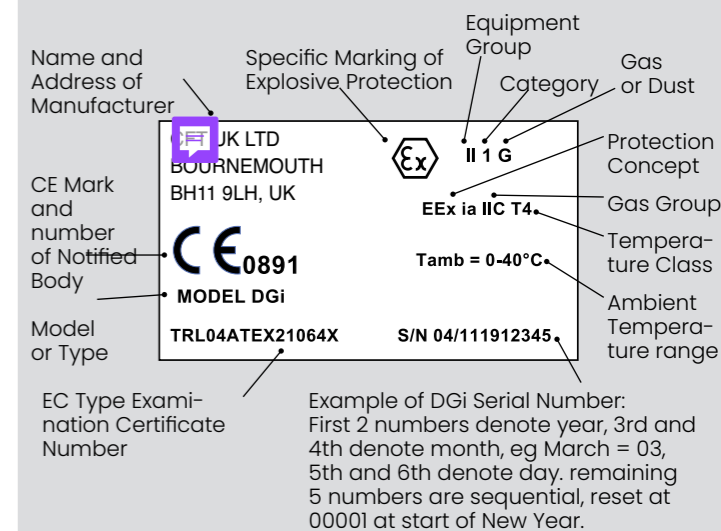

Typical Markings found on Sprayguns

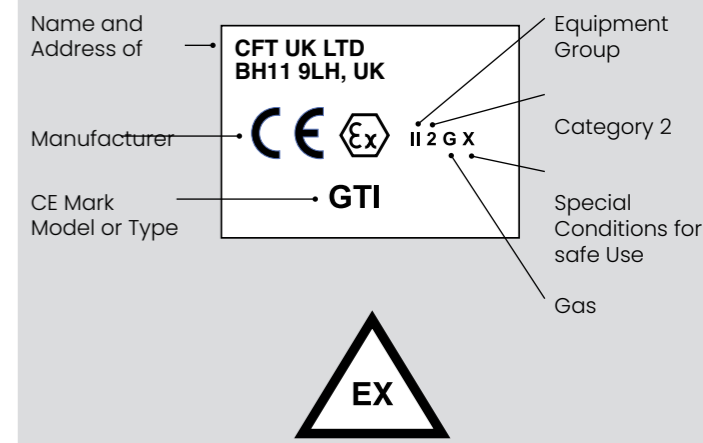



DeVilbiss Automotive Refinishing is a Binks brand featuring products designed to deliver premium finishes for the professional automotive repair shop. DeVilbiss brand products include low-pressure manual and automatic spray guns and related accessories, including air filter reducing valves and regulators, operator breathing systems and hoses.

A powerful solution can start with a simple conversation

We want to help build the best solution to your application challenges. Learn more about what we can offer, give us a call at +44 1202 571111 or visit us at **autorefinishdevilbiss.com**

Binks

India/SE Asia
Americas
EMEA
China
Japan Sales Office
Japan Binks/DeV

44.0.120 257.1111
1.800.992.4657
44.0.120 257.1111
86.21.33730108
81.45.785.6421
81.45.785.6421

marketing-roa@binks.com
marketing@binks.com
marketing-eu@binks.com
mkt_cn@binks.com
jp-rans-tokyosales@binks.com
jp-binks-devi@binks.com